

# The GLE Coupé



Mercedes-Benz



This Brochure is prepared by Daimler AG and it predominantly reflects the capabilities and performance of vehicles sold in Europe. Some characteristics, capabilities, performance features and optional extras (e.g. towing systems) may not be available or may not apply in Australia or under Australian conditions. The information in this Brochure is therefore indicative, illustrative and provided only for guidance and should not be relied on. To obtain current and accurate information on a vehicle and any options applicable to Australia, contact your local authorised Mercedes-Benz dealer. The declared fuel and energy consumption figures are determined by testing under standardised laboratory conditions to comply with ADR 81 /02. Real world fuel consumption is influenced by many additional factors such as fuel quality, individual driving style, load, traffic, and vehicle condition. The declared fuel consumption figure should only be used for the purpose of comparison amongst vehicles.



## Ready to make your mark?

Then take a seat. The new GLE Coupé is just made to let itself go and take every corner of the world by storm. With its sensationally sporty design. A revolutionary new cockpit. And a fully active suspension\* that sets the benchmark in its class.

\*Active suspension system is standard on all AMG variants. Available as optional equipment for all other variants.



Some personalities  
are hard to miss.

The new GLE Coupé really stands out. With a sensational design that is more sporty and stylistically confident than ever. A less upright windscreen, low body and sloping rear line form the elegant silhouette. Wheels\* of up to 55.9 cm (22 inches) in size emphasise the SUV character of the GLE Coupé.

\* 22 inch wheels are is standard on the GLE 63 S. Available as optional equipment for all other variants.



## Exhilaration for all the senses.

Inside you are welcomed by two large, fully digital instruments that share the same elegant glass cover. Also new are the high-quality seats which give the driver and front passenger tangibly more support, allowing even more dynamic motoring without compromising on comfort.

\*AMG Black ARTICO/ DINAMICA Upholstery is not available in Australia.



Get in. Then get out  
feeling more relaxed.

You can choose from 64 ambient colours as well as a range of different interior fragrances and massage programmes in the new GLE Coupé. Or activate an ENERGIZING\* programme such as "Vitality", in which case all these comfort features are coordinated automatically.

\*Energizing Package is standard on the GLE 63 S, optionally available on the GLE 53 and not available on the GLE 450.

The new GLE Coupé.  
An expression of inner strength.





## Head-up display.

The best outlook for sporty driving enjoyment and an assured driving experience: the head-up display transforms your windscreen into a stunning digital cockpit. This means you always have a direct view of key information. Your full attention remains on the road and the traffic conditions in front of you.

## Driving Assistance package Plus\*.

The Driving Assistance package Plus offers maximum comfort and safety on the road to autonomous driving. As a supplement to the Driving Assistance package you get Active Stop-and-Go Assist, which takes the strain off you on motorways. A further benefit of this package is PRE-SAFE® Impulse Side, which can provide additional protection in side-on collisions caused by other road users.

\*Standard on GLE 63 S and not available on other variants.



## Widescreen Cockpit.

Inspirational design meets a fully digital display with flexible presentation options: the Widescreen Cockpit enables information to be truly experienced. The desired content can be positioned individually and the host of functions controlled intuitively thanks to touch technology.

## MBUX Augmented Reality Navigation\*.

To enable you to find your way in complex traffic situations, MBUX Augmented Reality Navigation connects the virtual world with the real world. The technology incorporates graphical navigation instructions and traffic information into live images. So you reach your destination quickly, safely and stress-free.

\*Available as optional equipment as part of the Innovation Package.



Brushed aluminium trim is not available in Australia.



## ENERGIZING package Plus\*.

The ENERGIZING package Plus is unique. It provides the highest level of comfort for all the senses. To this end, a maximum of premium features are combined with innovative intelligence. The result is quite fascinating: your Mercedes can vitalise and cosset you in specific ways.

\*Energizing Package is standard on the GLE 63 S, Optionally available on the GLE 53 and Not available on the GLE 450.

## Burmester® high-end 3D surround sound system\*\*.

Sound on a par with that of luxury home music systems. Speakers in the roof liner compose a three-dimensional sound. They conduct the system like your personal orchestra – with VIP settings for individual seats or style settings such as “Live” or “Easy Listening”.

\*\*Burmester® high-end 3D surround sound system is optionally available on the GLE 63 S only.

## MULTIBEAM LED headlamps.

Giving you perfect visibility: the adaptive MULTIBEAM LED headlamps with individually controllable LEDs react to the traffic situation. Partial main beam blocks out other road users without dazzling them. When the road is clear, ULTRA RANGE Highbeam increases the range by 150 metres. The cornering and active light functions also light up the field of vision in optimal style.

## Wheels\*\*\*.

Another highlight: wheels of up to 55.9 cm (22 inches) in size clearly emphasise the SUV character of the new GLE Coupé.

\*\*\*22 inch wheels are is standard on the GLE 63 S. Available as optional equipment for all other variants.



## The AMG Line.

Expressive styling for an impressive appearance: the AMG Line exterior sharpens the sporty character of your vehicle and clearly differentiates it from the base model. The visual effects make your vehicle look lower and more dynamic, allowing you to make a clear statement in support of powerful design. The AMG Line interior lends your vehicle a more visible and tangible sense of sportiness. As such you can make a tasteful statement and demonstrate your passion for an ambience which is dynamic and exclusively designed, down to the finest detail.



## The Night package.

More character – expressive style. In combination with the AMG Line, the Night package adds striking highlights in the form of exclusive black design features. These accentuate the sporty character and athletic design idiom of your vehicle. Ideal for individualists who appreciate an expressive design.



# Not an SUV. An AMG.

Every Mercedes-AMG is a masterpiece in its own right, with an unmistakable character. What unites our performance vehicles and sports cars is their irrepressible sporting spirit. Their passion for top performance. It is generated at the point where engineering skill meets a very special attitude: the spirit of AMG. We believe that you have to keep on challenging limits in order to achieve new goals. We accept nothing as a given. Because limits are imposed by people, and it's also people who can overcome them. It's this attitude that enables us to achieve outstanding performance for motor racing – and for the road.

Welcome to the world of AMG.

[www.mercedes-amg.com](http://www.mercedes-amg.com)

**AMG**  
DRIVING PERFORMANCE



## Technical data.

	Petrol engines		
	GLE 450	GLE 53	GLE 63 S
Displacement (cc)	2999	2999	3982
Rated output <sup>1</sup> (kW [hp] at rpm)	270 [367]	320 [435]	450 [612]
Acceleration from 0 to 100 km/h (s)	5.7	5.3	3.8
Fuel consumption <sup>4</sup> (l/100 km)			
Urban	11.7	11.7	17.5
Extra-urban	7.9	7.9	9.8
Combined	9.2	9.3	12.6
Combined CO <sub>2</sub> emissions <sup>4</sup> (g/km)	213	212	286

The best for the engine:  
Mercedes-Benz genuine engine oils.

The declared fuel and energy consumption figures are determined by testing under standard laboratory conditions to comply with ADR 81/02. Real world fuel consumption is influenced by many additional factors such as fuel quality, individual driving style, load, traffic, and vehicle condition. The declared fuel consumption figure should only be used for the purpose of comparison amongst vehicles. For more technical data, please visit [www.mercedes-benz.com.au](http://www.mercedes-benz.com.au).

## Dimensions.

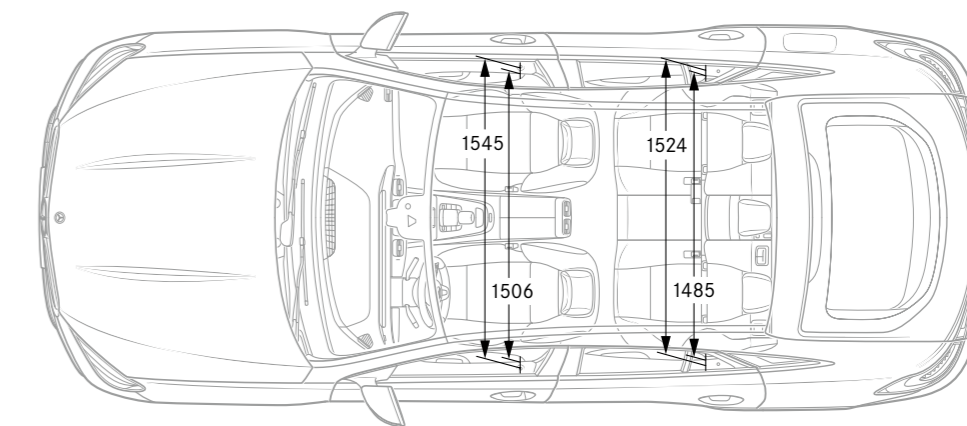
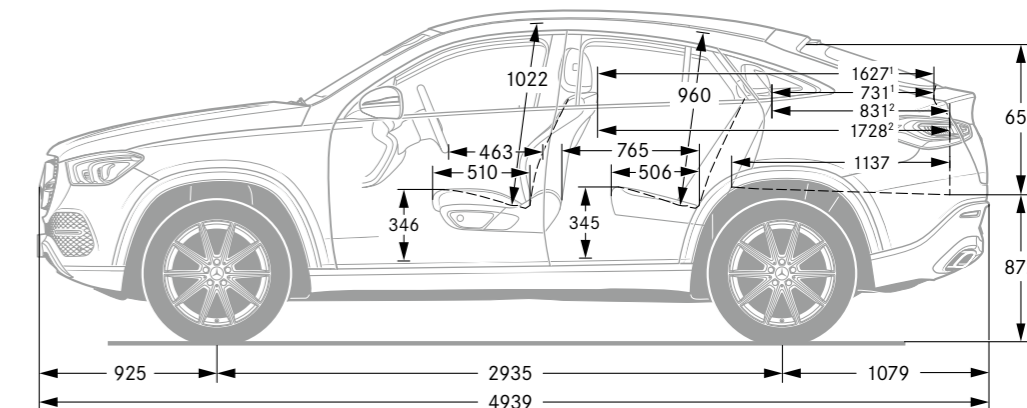
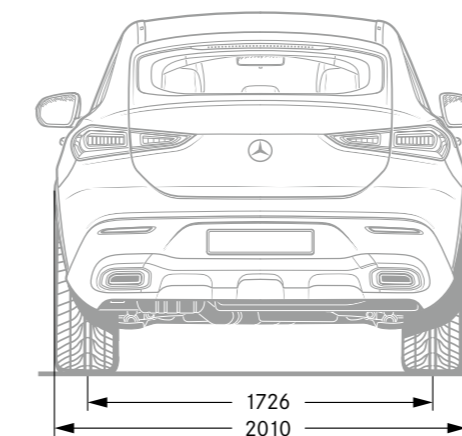
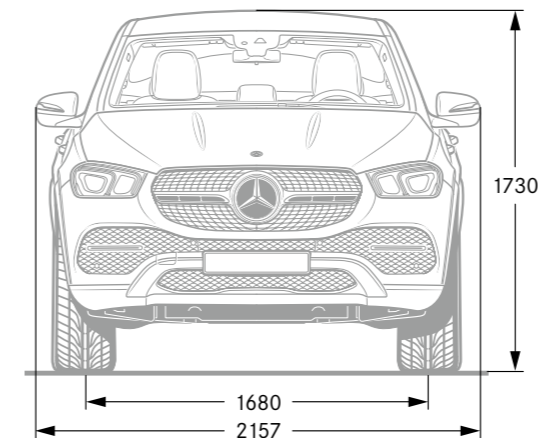

<sup>1</sup> Up to parcel shelf connecting edge. <sup>2</sup> Below the parcel shelf. All figures in millimetres. The illustrated dimensions are averages. They are valid for vehicles in basic specification and in unladen condition.



# SPORT — F O R — GOOD

Mercedes-Benz AG is one of the founding partners of the worldwide “Laureus Sport for Good Foundation”, which was established in 2000. It is the Mercedes-Benz brand’s most important social initiative. Laureus Sport for Good supports children and young people in need through social sports projects, opening up new perspectives and imparting important values such as team spirit, respect and determination. “Change the Game for Kids” is our mission statement which we wish to share with you. In buying a Mercedes-Benz you are supporting the “Laureus Sport for Good” movement.

**Please note:** Please note: changes may have been made to the product since the editorial deadline (15.05.2019). The manufacturer reserves the right to make changes to the design, form, colour and the product specification during the delivery period, provided these changes, while taking into account the interests of the vendor, can be deemed reasonable

with respect to the purchaser. The illustrations may show accessories and items of optional equipment which are not part of standard specification. This publication is distributed internationally. For current and more specific information, please contact your nearest authorised Mercedes-Benz retailer. [www.mercedes-benz.com.au](http://www.mercedes-benz.com.au)



AMG



The all-new  
Mercedes-AMG GLE 53  
4MATIC+ Coupé.

## Passion finds a home.

Every great story begins with a dream. And the AMG story is no different. In the 1960s, the passion of two automotive engineers, Hans Werner Aufrecht and Erhard Melcher knew no bounds. They dreamt of transforming regular cars into performance powerhouses. Employed at the Development Department at Daimler-Benz, they would spend all of their spare time honing their passion and perfecting engines at Aufrecht's house in Großaspach. Their exceptional work on the 300 SE engine made their friend, a Mercedes-Benz racecar driver, win ten races and made the duo a popular force on the racetrack.

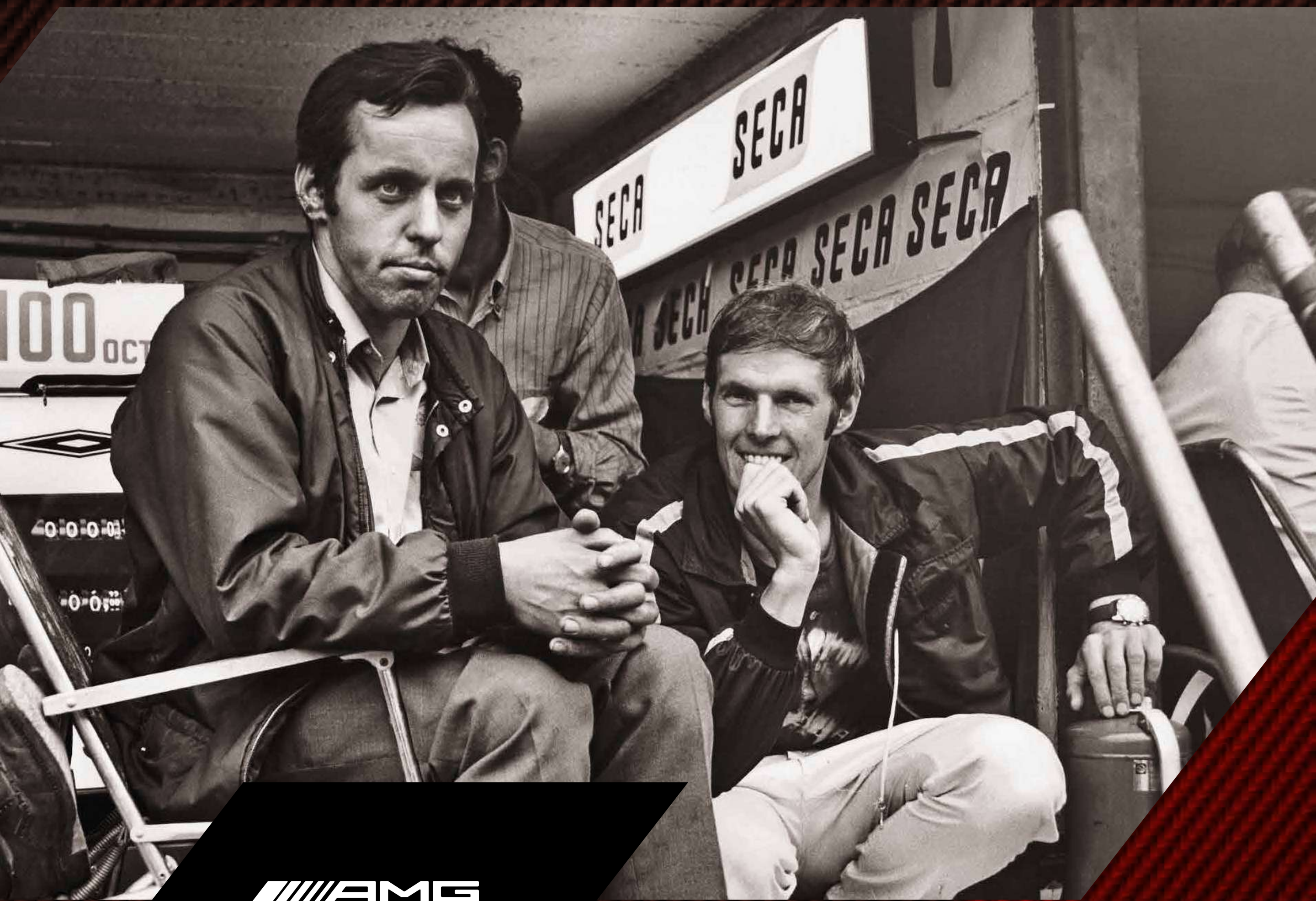

**AMG**

Following the new success, they moved to an old mill in Burgstall to continue pursuing their passion and founded AMG in 1967 (A for Aufrecht, M for Melcher and G for Großaspach).

## AMG opens its wings in India.



For over 10 years, the AMG brand in the country has reigned over the hearts of performance car enthusiasts and those who are passionate about driving performance. The launch of SLS AMG in 2010 took the country by storm as India was among the first right-hand-drive markets to launch the Gullwing within the first few weeks of its production. In 2011, India witnessed the launch of one of the most iconic SUVs ever made.

A true champion with countless stories of adventure and an unmatched legacy of over 40 years, this Star proved that its DNA was stronger than time. This was the Mercedes-AMG G 55 that enthralled audiences and became the flag-bearer of the fierce AMG engineering in India. In subsequent years, the onslaught of AMGs has progressively created quite a stir with multiple AMGs right from the 43s, 45s, 63s to the GT series ruling the Indian roads. Now, it's time to up the ante with a new benchmark of power and precision: The Mercedes-AMG GLE 53 4MATIC+ Coupé.



## The first in the powerful 53 Series in India.

AMG introduced a new performance level in the shape of the 53 Series. Launched in 2018 globally as the first step towards hybridized future with a leading-edge combination of sporty design, performance & efficiency. Formidable six-cylinder performance and race-bred driving dynamics are the cornerstones of the AMG 53 range. Add in head-turning exterior styling and standout interior design and you have some of the most captivating vehicles in the AMG stable.

As AMG completes 53 years globally, we are bringing the powerful 53 series to India for the first time.





**A DESIGN IDIOM THAT'S  
THE TALK OF THE TOWN.**

*\*Please read the disclaimer.*

## Ready to make your mark? Then take a seat.

The all-new Mercedes-AMG GLE 53 4MATIC+ Coupé is made to let itself go and take every corner of the world by storm. A sporty, elegant coupé design, outstanding off-road capability and typical AMG on-road driving dynamics: this combination is what makes the all-new Mercedes-AMG GLE 53 4MATIC+ Coupé so special on the road and far beyond.



*\*Please read the disclaimer.*

## 3.0-litre 6-cylinder In-line Turbo Engine

POWER AND  
PERFORMANCE

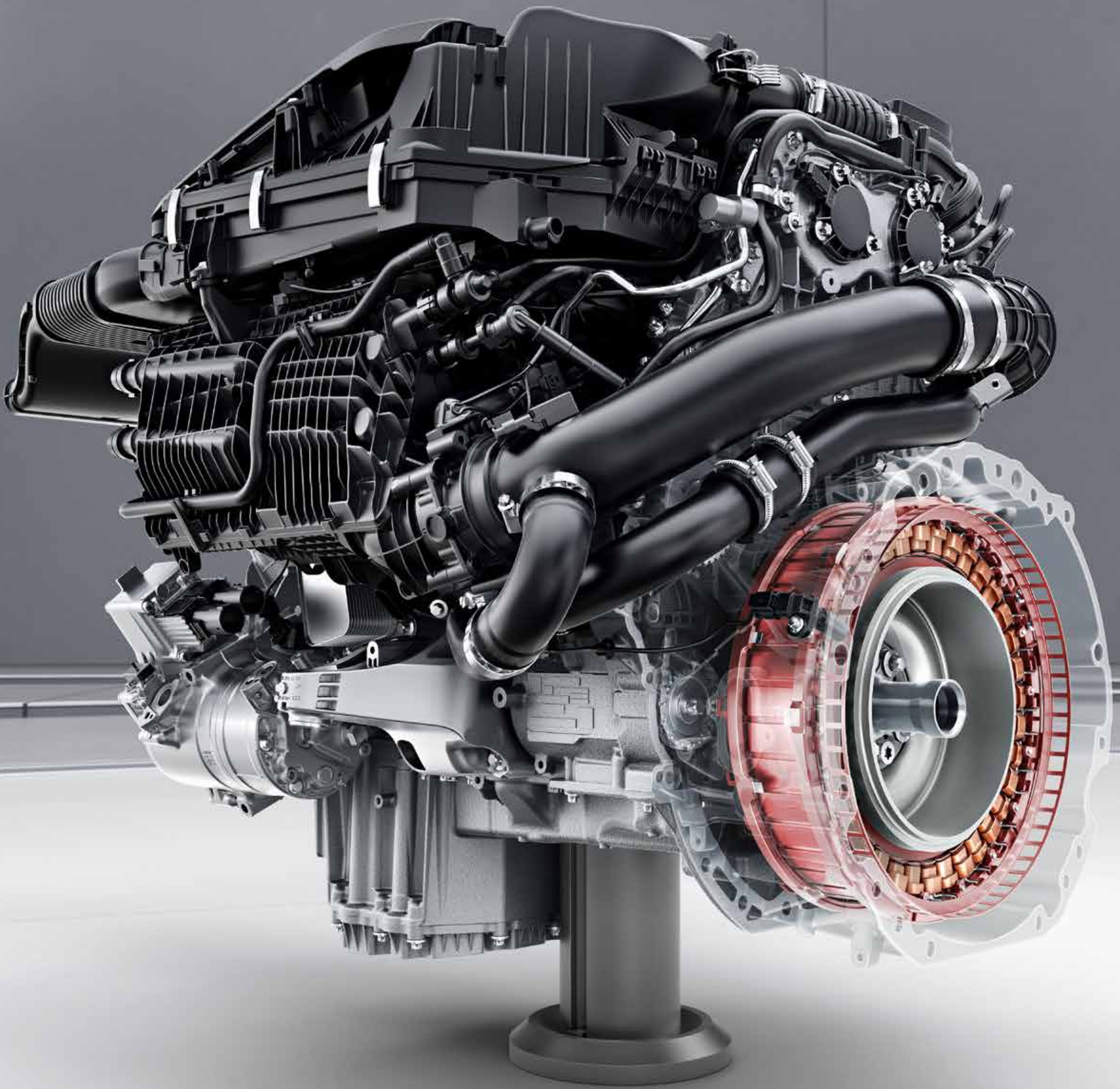

The 3.0-litre 6-cylinder in-line turbo engine and the dynamic AMG Performance 4MATIC+ all-wheel drive with fully variable torque distribution in the Mercedes-AMG GLE 53 4MATIC+ Coupé ensure a spectacular driving experience. The integral starter-alternator delivers additional output through boosting and recovers highly efficient energy through recuperation. The performance of the six-cylinder in-line engine rated at 320 kW is thus additionally boosted by up to 16 kW. The modern 48-volt on-board electrical system enables the use of new technologies – it delivers reliable energy and in doing so guarantees the full driving force. The additional electric compressor delivers torque barely above idle speed, thus ensuring particularly sporty torque levels. Twin-scroll turbocharger with air/water charge-air cooling and two-flow exhaust routing – the ducts, each from two cylinders, are separate and come together only just before the turbine. This dethrottles the exhaust system and the engine responds more directly to accelerator pedal commands.

## AMG Speedshift TCT 9G

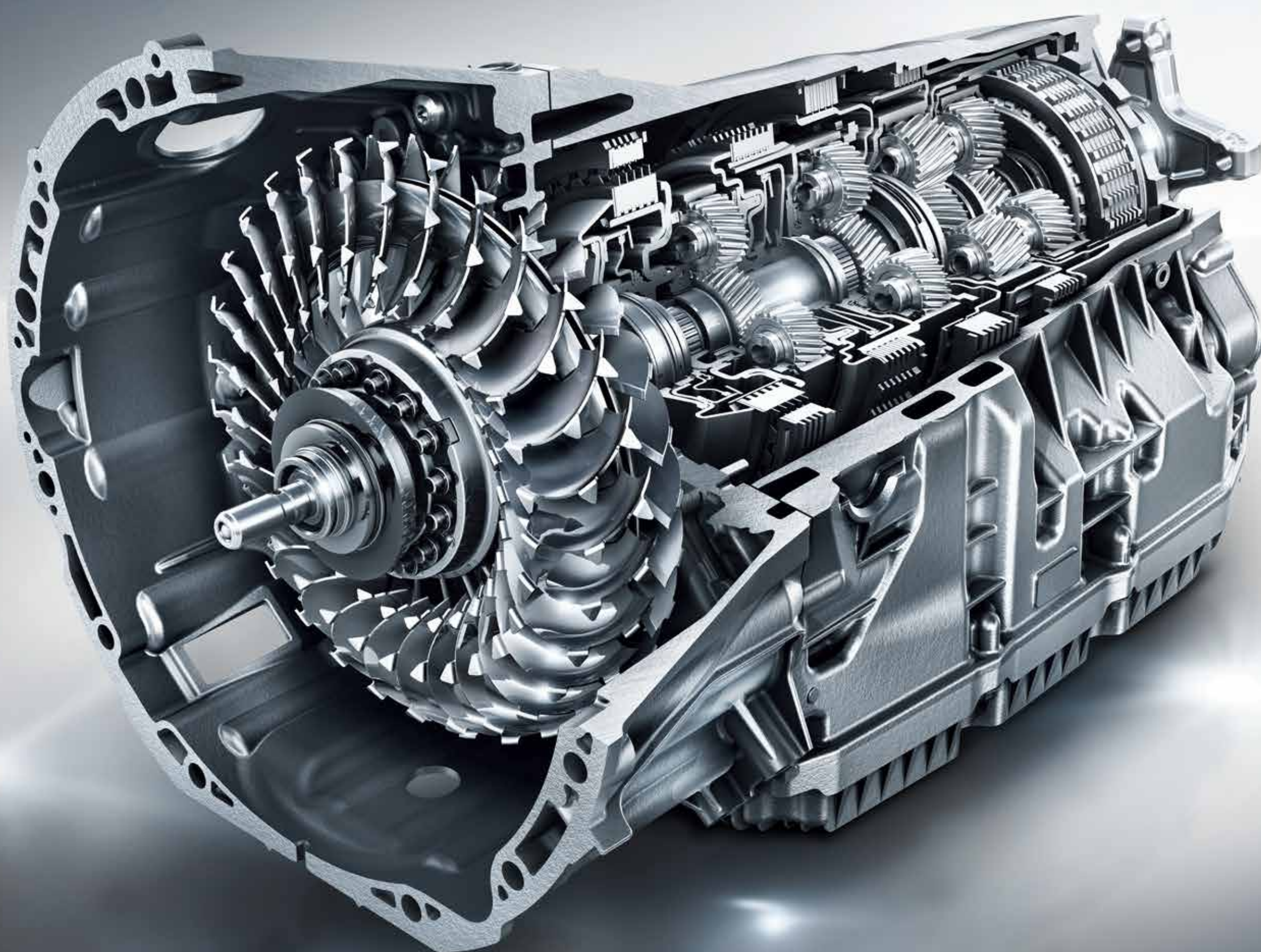

9 gears enable low engine speeds, reducing the fuel consumption and ensuring quieter running. The AMG SPEEDSHIFT TCT 9G impresses sporty drivers with dynamic shift characteristics and the emotively appealing double-clutching function. With the drive programs it masters fast, sporty gear-changing or comfortable, barely noticeable shift operations.

The AMG SPEEDSHIFT TCT 9G combines efficiency, dynamism and safety. If necessary, the torque converter switches to a lower gear in an instant via multiple downshifting in order to call up the engine's full output.

# AMG Performance 4MATIC+ all-wheel drive

POWER AND  
PERFORMANCE



The performance-oriented all-wheel drive steplessly calculates the optimum torque distribution depending on the driving conditions and motorist's requirements. The motorist thus benefits from the advantages of both a traction-oriented all-wheel drive system and a pure rear-wheel drive system.

4MATIC+ all-wheel drive at a glance:

- Experience AMG Driving Performance, thanks to 4MATIC+ with variable power distribution
- Delivers longitudinal and lateral dynamics
- Noise reduction
- Optimum traction
- High driving stability and handling safety
- Variable connection between the permanently driven rear axle and the front axle

## AMG RIDE CONTROL+

POWER AND  
PERFORMANCE



Outstanding agility meets excellent controllability. The AMG ACTIVE RIDE CONTROL+ with active roll stabilization intelligent suspension based on 48 V Technology provides optimum conditions when adopting a sporty driving style both on and off the road. This suspension with AMG-specific kinematics, elastokinematics and stepless damping control lets you choose the setup where you can use the firm sport setting for optimum handling when pushing to the critical limits and at maximum speed. Or the comfort setting for softer, balanced damping characteristics, like on long journeys. The AIRMATIC package comes as part of the AMG RIDE CONTROL+ and offers the following:

- Comfort benefits of a modern air suspension system with adaptive damping system ADS+
- Automatic level control depending on vehicle speed, drive program and load

# AMG Dynamic Drive



AMG Dynamics comprises the intelligent control electronics for all vehicle-specific agility functions, for example steering, torque distribution, all-wheel drive and active stabilisers. The motorist can select from the following AMG DYNAMIC SELECT drive programs:

- "C" (Comfort): balanced drive program with comfortable suspension.
- "S" (Sport): greater agility and dynamics with sporty and firm suspension tuning and spontaneous throttle response
- "S+" (Sport+): further enhanced sportiness owing to higher dynamic tuning of the suspension and drive system
- "Slippery": for optimised handling on icy and snow-covered roads
- "Trail": for roads and tracks with a loose surface, e.g. gravel and also unpaved forest paths and country tracks
- "Sand": for optimum handling on sand and sandy roads
- "I" (Individual): provides the option to adjust the parameters for the drive system, AMG Dynamics, suspension and steering, among other things, according to personal preferences

Manual "M" mode selectable via M button: provides the option of carrying out shift commands manually in any drive program via the steering wheel shift paddles

## AMG Performance Exhaust System, selectable

POWER AND  
PERFORMANCE



The variably adjustable exhaust flaps give you the option to change the sound of the vehicle at the press of a button. Depending on the drive mode, the sound characteristics change from unobtrusive comfort to maximum emotive appeal. The easily audible double-declutch plus the controlled misfires make your driving experience even more emotionally appealing.





Not just a means of arrival at your destination, the new Mercedes-AMG GLE 53 4MATIC+ Coupé is a thoughtful companion through your journey. The Fit & Healthy features understand, motivate and guide to keep you in the prime of your health while driving. Get ready to elevate your driving experience with a car that cares.

Something special.

On every trip, from any angle.

With the **Fit & Healthy** features.



64 Colour Ambient lighting | AMG RIDE CONTROL+ |  
4-way Lumbar Support | ENERGIZING Seat Kinetics |  
Climatised Seats | Burmester® surround sound system |  
Memory Package



## Athletic with chiselled corners and edges.

The all-new Mercedes-AMG GLE 53 4MATIC+ Coupé boasts an exterior design that really stands out. With a sensational design that is more sporty and stylistically confident than ever.

A less upright windscreen, low body and sloping rear line form an elegant silhouette. What's more? The 53.3 cm (21-inch) AMG Alloy wheels emphasizes the sporty SUV character of the all-new Mercedes-AMG GLE 53 4MATIC+ Coupé.

## MULTIBEAM LED



The adaptive MULTIBEAM LED headlamps with 84 individually controllable LEDs react to the traffic situation - When the road is clear, the ULTRA RANGE Highbeam increases the range upto 650 metres. The cornering light and active light functions also illuminate the field of vision with roundabout and cross-traffic functions. The car comes with an adaptive all-LED tail lights.

### Key Highlights:

- Active light function
- Enhanced fog light function, city light, country mode, motorway mode and adverse weather light



## AMG Night Package

Demonstrating your sense of individuality, dynamic design and superior reserve with the AMG Night Package.



- » Exterior elements in high-gloss black:  
Front splitter and trim strip in the AMG front apron | Exterior mirror housing, painted | Window weather-strips | Trim strip in AMG rear apron



AMG exhaust system with 2 black chrome-plated twin tailpipe trim elements

## Alloy Wheels



53.3 cm (21-inch) AMG 5-twin-spoke light-alloy wheels

## AMG Spoiler Lip



The AMG spoiler lip painted in the vehicle colour reduces lift at the rear axle, thus supporting neutral handling characteristics at high speeds.

## Panoramic Sliding Sunroof



With the panoramic sliding sunroof, you experience a wonderful feeling of freedom and enjoy a pleasantly bright ambience.

Key highlights:

- Large glass module of tinted safety glass
- Net wind deflector in the front section
- Electric roller sunblind with one-touch control
- Comprehensive safety concept:
  - Obstruction sensor
  - Automatic rain closing function
  - PRE-SAFE<sup>®</sup> closing function

## Mirror Package



The Mirror Package makes everyday driving easier: Electrically folding outside mirrors help protect your vehicle against damage when parking. Getting in and out of the vehicle in the dark is more convenient with the surround lighting. An attractive, eye-catching feature is the projection of the brand logo next to the opened side doors.

## Illuminated Running Boards



An attractive feature is the illuminated, aluminium-finish running boards mounted on the side at the height of the side skirts. Slip-resistant rubber studs ensure a firm foothold.

## Exhilaration for all the senses.

Inside you are welcomed by two large 12.3" fully digital screens, that share the elegant seamless glass panel. Also new are the high-quality sports seats which gives the driver and the front passenger tangibly more support, allowing even more dynamic motoring without compromising on comfort.





# Hey Mercedes

MBUX features in the all-new Mercedes-AMG  
GLE 53 4MATIC+ Coupé.



## NATURAL VOICE CONTROL

"Hey Mercedes." These two initial words start the natural, intuitive LINGUATRONIC voice control system which comes as standard. It reacts to almost every word. The system can even process indirect speech – the air conditioning will respond, e.g. to "I feel cold" and increase the temperature. At the same time the voice control also has learning capability. It attunes itself to your voice and thus understands you better.

# Hey Mercedes

MBUX features in the all-new Mercedes-AMG GLE 53 4MATIC+ Coupé.



## DISPLAY STYLES

You can customise the design and the entire look and feel of the Widescreen Cockpit. There is a choice of five display styles: "Classic", "Sport", AMG specific "Supersport", "Understated" and "Standard". The chosen style tangibly characterises the interior atmosphere, especially in conjunction with the available ambient lighting.



## TOUCH CONTROL CONCEPT

MBUX offers users maximum freedom for controlling all functions in the way most comfortable and convenient to them. Whether using voice control or intuitive touch functions. The new Mercedes-AMG GLE 53 4MATIC+ Coupé comes with the option of a multimedia touch display. There is also a touchpad integrated in the centre console, which responds to single and multi-finger gestures as well as handwriting. Furthermore, the displays can be controlled using Touch Control buttons on the steering wheel.

# AMG Performance Steering Wheel in Nappa leather/ DINAMICA Microfibre



In this AMG steering wheel, fine nappa leather comes together with grippy DINAMICA microfibre for precise control along with ergonomically positioned Touch Control buttons ensuring intuitive user-friendliness that are conducive to focused driving.

## AMG Steering Wheel Buttons



With the AMG steering wheel buttons, you can make your steering wheel even sportier. They allow fast, purposeful control of specific dynamic driving functions for a focussed and concentrated driving sensation giving an authentic racing car atmosphere in the cockpit.

# Head-up Display



The head-up display is for ideal perspectives for sporty driving pleasure and a sheer superior driving experience transforming your windscreen into an exciting digital cockpit. You always have a direct view in front of you along with key information. In the new design, information is displayed in high-resolution and in color. Thanks to a special light sensor, the brightness automatically adjusts to the external light conditions.

Components of Head-up Display:

- Lens and mirror system projects a virtual image measuring approx. 24 x 8 cm into the driver's field of view
- Wedge-shaped composite film for the windscreen (compensates for reflections)
- Depending on equipment, display of navigation tips, speed, speed limits or settings for cruise control

## Widescreen Cockpit



Inspirational design meets a fully digital display with flexible presentation options that enables information to be truly experienced. The desired content can be positioned individually and the host of functions controlled intuitively thanks to touch technology. Display cluster comprises of 2 fully digital color displays, each with a screen diagonal of 12.3 inches and a resolution of 1920 x 720 pixels with AMG specific content.

## Smartphone Integration



Smartphone Integration merges the mobile phone with the infotainment system via Apple CarPlay™ and ANDROID AUTO® for convenient access. The voice control is more than just an appealing feature as you can submit your requests via the voice assistants in the car.

## 3D Hard-disc Navigation



Save time through fast hard-disc navigation with flexible inputs via touch control or voice input. The intelligent system guides you reliably to your destination using both local as well as up-to-date data and 3D Maps. The high-quality 2D or 3D map displays recommend the ideal lane for your next driving manoeuvre. The system will first determine your desired route. This can be the fastest way or, for example, a route without tolls. You enter the data as you wish – on the touch screen, or using the touchpad, the Touch Control buttons or LINGUATRONIC. Another special feature is “what3words” where the system determines every single point on earth with exactly three words.

# Burmester® Surround Sound System



Experience more performance and exclusivity with the legendary Burmester® sound. You can specifically optimize this for the front and rear seats to intensify the listening experience.

- 13 high-performance speakers
- 9-channel DSP amplifier with a total output of 590 watts
- Frontbass technology with subwoofers integrated into the body shell
- Supports multichannel formats for true surround sound



## 64 color Ambient Lighting



Showcase the interior according to your personal preferences or current mood, with a total of 64 colors, that gives you almost unlimited scope for lighting schemes, and has the right color available for any situation.

## Illuminated AMG door sill panels with »AMG« lettering



## Interior Chrome Package



The Chrome package lends the interior with numerous surrounds finished in stylish silver chrome offering a higher-quality ambience to your interior.

- Chrome-plated controls and trim in the door panel area
- Controls on left next to the steering wheel
- Hand comforter, control switches and cup holder in the centre console
- Control bar for climate control



# Trim



Metal-weave trim with Dashboard and Beltlines in ARTICO

## AMG Sports Seats



AMG Seats for driver and front passenger that provides optimum lateral support and features an AMG-specific seat upholstery layout, with "AMG" badge in the front seat backrests.

## Sporty Seat Belts

Gear Up before you GEAR UP!



Seat belts in Red



Seat belts in Black

## Memory Package



The Memory Package provides practical ease of operations:

- Electrically adjustable front seats, Fore-and-aft seat, head restraint height position of steering column and exterior mirrors. One can also save/store these positions.
- 4-way lumbar support for driver and front passenger
- Seat cushion length adjustment with gapless cushion
- ENERGIZING seat kinetics
- PRE-SAFE® positioning function for front-passenger seat
- Front-passenger seat control for the driver
- Electrically adjustable height of the head-up display

## Climatised Front Seats



The climatized seats for driver and front passenger comprise 3-stage seat heating and seat ventilation for an ideal seat climate all year round.

## 4-Zone THERMOTRONIC automatic climate control system



Adjustment of the temperature and airflow is convenient and intuitive. The automatic climate control and a highly responsive sensor system comforts you as the settings can be kept constant for each climate zone. No subsequent, manual adjustments are necessary for changing weather conditions or sunshine. Especially for the driver, the constantly balanced interior climate has a positive effect on concentration and fitness. The integral activated charcoal particle filter works very efficiently, and besides dust and soot particles also eliminates pollen, harmful substances and unpleasant odours.

## Additional USB ports



Charge smartphone or tablet quickly – the car is equipped with total of 5 additional USB-C ports. Via selected connections, devices can also be connected directly to the vehicle's multimedia system and controls.

## Wireless Charging



Just drop your smartphone into its allotted place in the oddments tray for wireless charging. Irrespective of the model and brand, compatible smartphones (Qi standard) are charged wirelessly.

## Media Interface cable kit

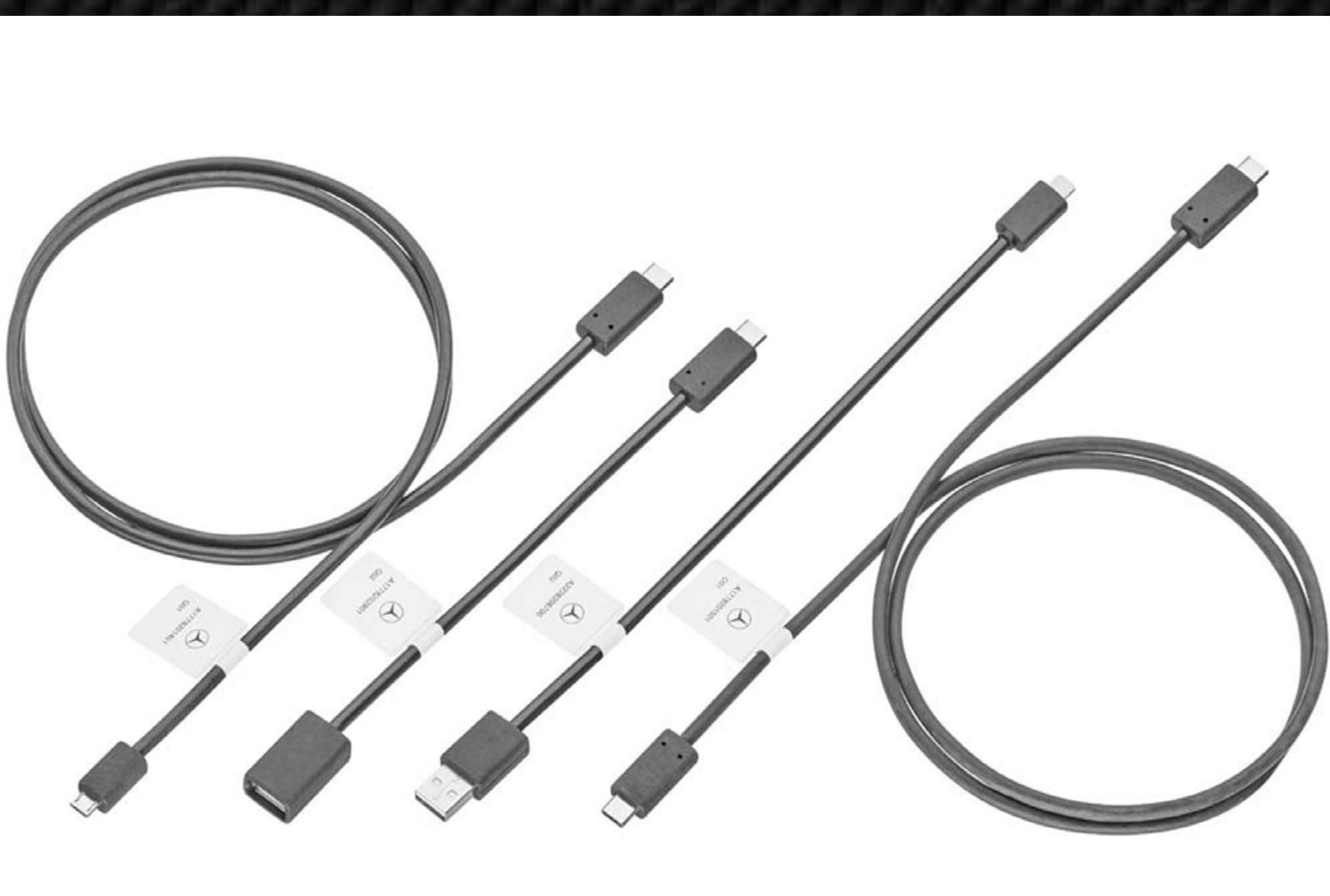

With the practical cable kit you can connect your devices with USB or Lightning port to your vehicle's multimedia system via a universal interface.

## EASY-PACK Tailgate



Extremely practical, this feature opens and closes electrically at the press of a button, which makes loading and unloading the boot even more convenient.

## Dividing net for partitioning and protection



This equipment can increase protection of the occupants more effectively against objects that have not been secured in the luggage compartment. The dividing net can be fitted behind the front seats or the 2<sup>nd</sup> seat row and is very simple to use, all it takes is just a few steps.



# Mercedes me

The all-new Mercedes me app with a redesigned user interface, simpler navigation and enhanced features.



- » Geo-fencing – Set a perimeter for the car movement and receive notifications if the vehicle moves beyond it.
- » Open/Close the windows and sunroof remotely through the app.
- » Vehicle Finder - Find your vehicle by simply blowing the horn or flashing the headlamps through the app.
- » Mercedes me Service APP - Your digital assistant to keep a tab on your Star's maintenance with ease.



The expected 'over the air' release for these new features will happen soon. Post OTA update in car, features would be visible in the all-new Mercedes me 2020 App.

Please note that certain services are offered free of cost for a period of three (03) years and may be chargeable at the expiry of three (03) years from the date of activation of such services. If you wish to continue using those services, you may renew the same through Mercedes Me Store (as and when it is available). Please get in touch with your preferred Franchise Partner for more details.

# Mercedes me

Mercedes me connect allows drivers to stay in touch with their vehicles from anywhere in the world, and to obtain assistance at the touch of a button.

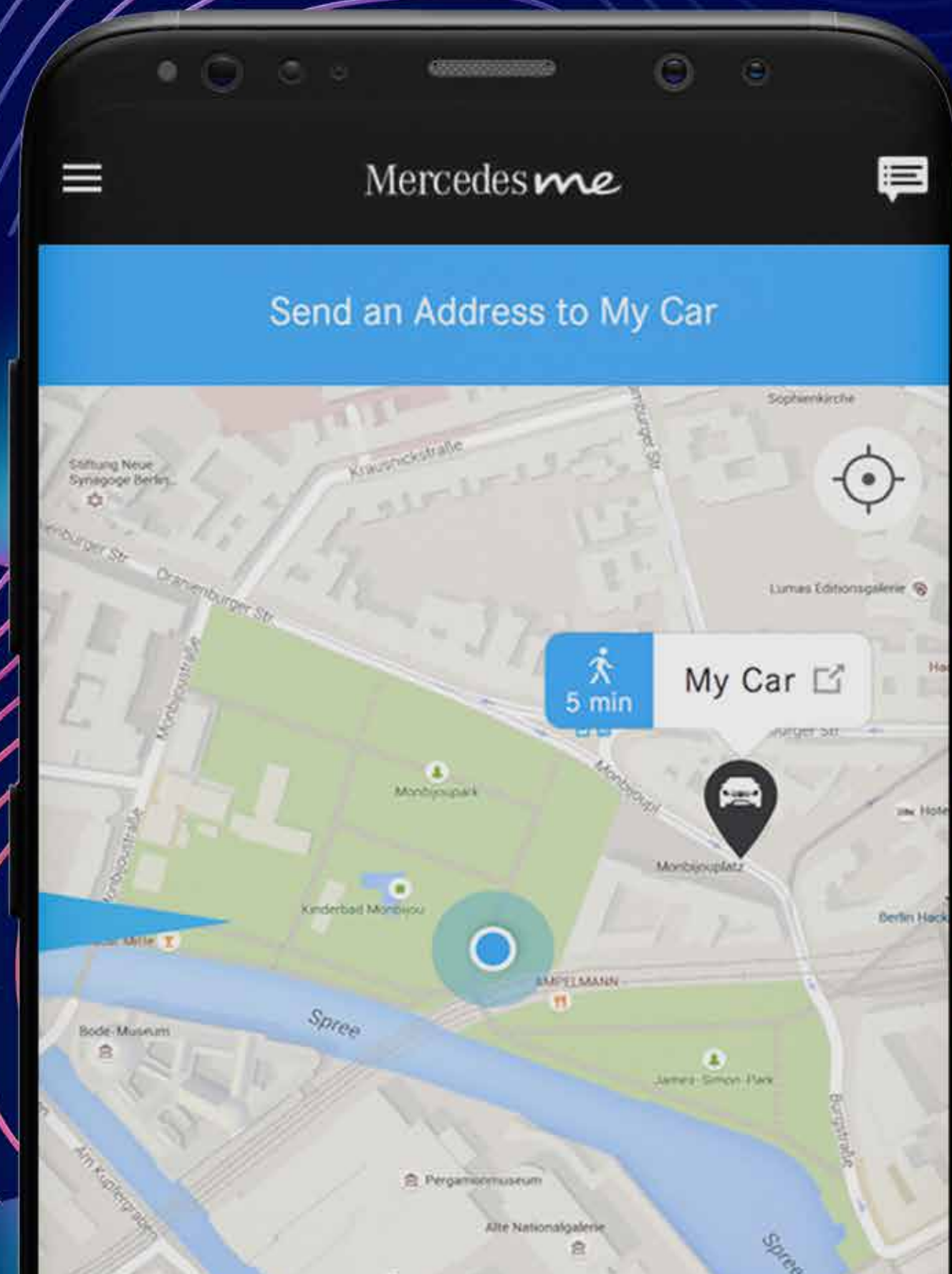

## Vehicle Monitoring:

- » Parked Vehicle Locator - Locate your vehicle within a radius of 1.5km
- » Vehicle Tracker - Get your vehicles geo-coordinated by GPS
- » Notification - Receive an alert if the vehicle exceeds a certain speed

## Vehicle Set-up:

- » Remote Engine Start
- » Remote Retrieval of Vehicle Status
- » Remote Door Locking and Unlocking
- » Speed Alert
- » Send your address to your vehicle

## Navigation Connectivity Package:

Reach your destination on time with communication module (LTE) and the hard-disc navigation.

## Mercedes-Benz Emergency Call System:

In case of an accident a communications module with its own SIM card automatically triggers an emergency call.

Please note that certain services are offered free of cost for a period of three (03) years and may be chargeable at the expiry of three (03) years from the date of activation of such services. If you wish to continue using those services, you may renew the same through Mercedes Me Store (as and when it is available). Please get in touch with your preferred Franchise Partner for more details.

## 3-stage Electronic Stability Program (ESP®)



ESP® with permanently active traction logic ensures that the engine output is transferred to the road to optimum effect thanks to targeted braking intervention in the event that one of the drive wheels starts to spin. ESP® system is adjusted via AMG Dynamics agility functions to the desired vehicle characteristics. 3 individual control strategies are available using the ESP® button:

- ESP® ON: for high safety when adapting the system to the sporty character
- ESP® SPORT HANDLING MODE: for enhanced vehicle dynamics – with special tuning of over and understeer intervention plus engine torque intervention
- ESP® OFF: targeted deactivation of the ESP® system for very sporty driving manoeuvres on closed-off race circuits or for off-road routes

# AMG Braking System



Benefit from excellent deceleration rates in any situation: The AMG high-performance braking system is your reliable partner when speed needs to be metered precisely and reduced accurately. The generously dimensioned brake discs are ventilated all-round.

## MAGIC VISION CONTROL



Greater visibility, greater safety with the innovative MAGIC VISION CONTROL system. It ensures perfect visibility even during the wiping process. Highly efficient windscreen wiper system comprising control unit, position sensor, electric pump and distributor rail.

## Adaptive Highbeam Assist Plus



Drive with permanent main beam: This virtually turns night into day and takes the strain out of driving. Key highlights;

- Automatic main-beam control for permanent broad illumination of the carriageway
- Partial switching-off of the LEDs of the MULTIBEAM LED main-beam modules to avoid dazzling vehicles in front or oncoming traffic
- Active from a speed of 30 km/h on roads with no street lighting

## Blind Spot Assist



It is a radar-based assistance system function with 2 radar sensors on the rear bumper sides. Taking a close look, the system gives you a visual and audible warning of impending side collisions with other road users in the blind spot. After your trip, the system still remains alert and warns you if you open the door at the wrong time.

## Active Brake Assist

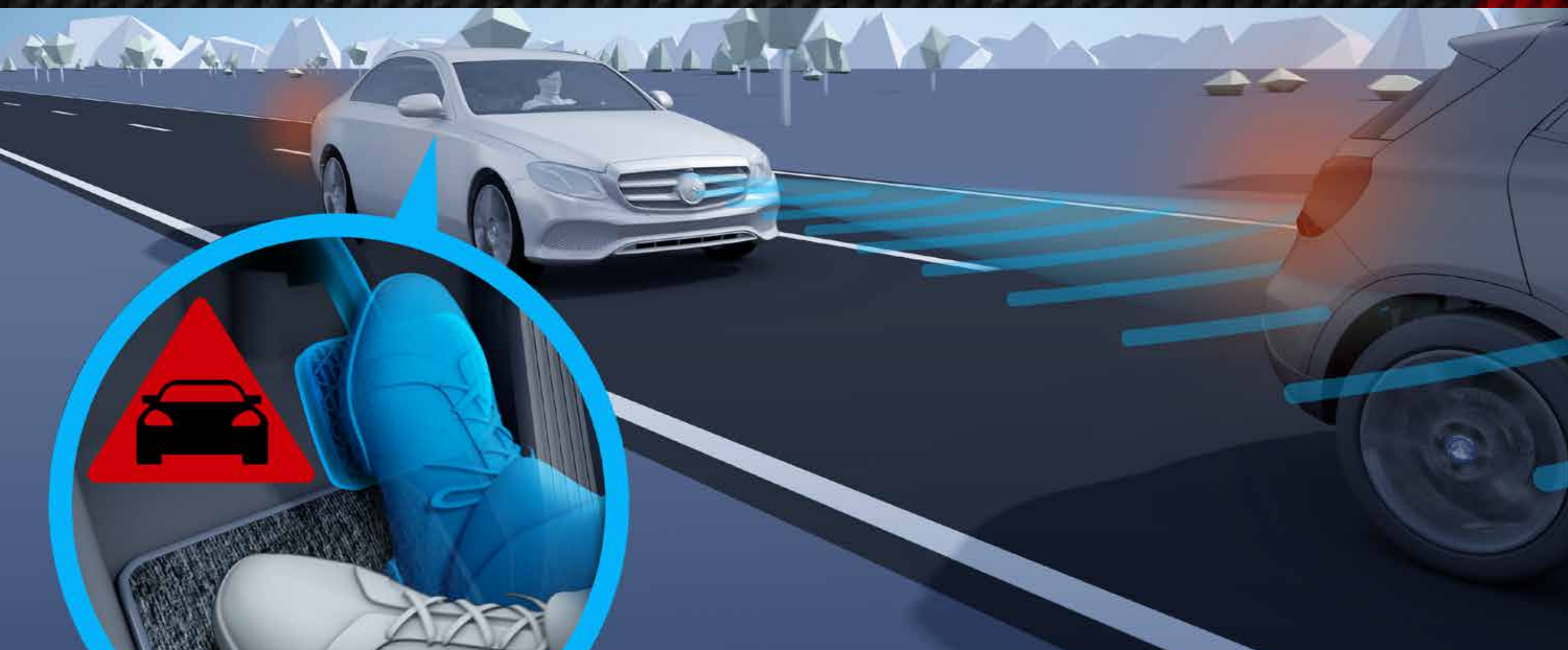

It helps you avoid rear-end collisions with vehicles in front or stationary vehicles as well as accidents with moving pedestrians or cyclists. It offers braking assistance in accordance with the situation – right up to autonomous emergency braking.

# Parking Package with 360-degree camera



Manoeuvre effortlessly, park precisely: thanks to all-round visibility you master even narrower or angled parking spaces at the first attempt. With the 360° camera you have a view of every angle around your vehicle. The virtual bird's-eye view is a smart way to show you where you stand.



# Upholstery



AMG Nappa Leather, Two-tone Black



AMG Nappa Leather, Two-tone Truffle Brown / Black



# Paintwork

Non-Metallic

designo

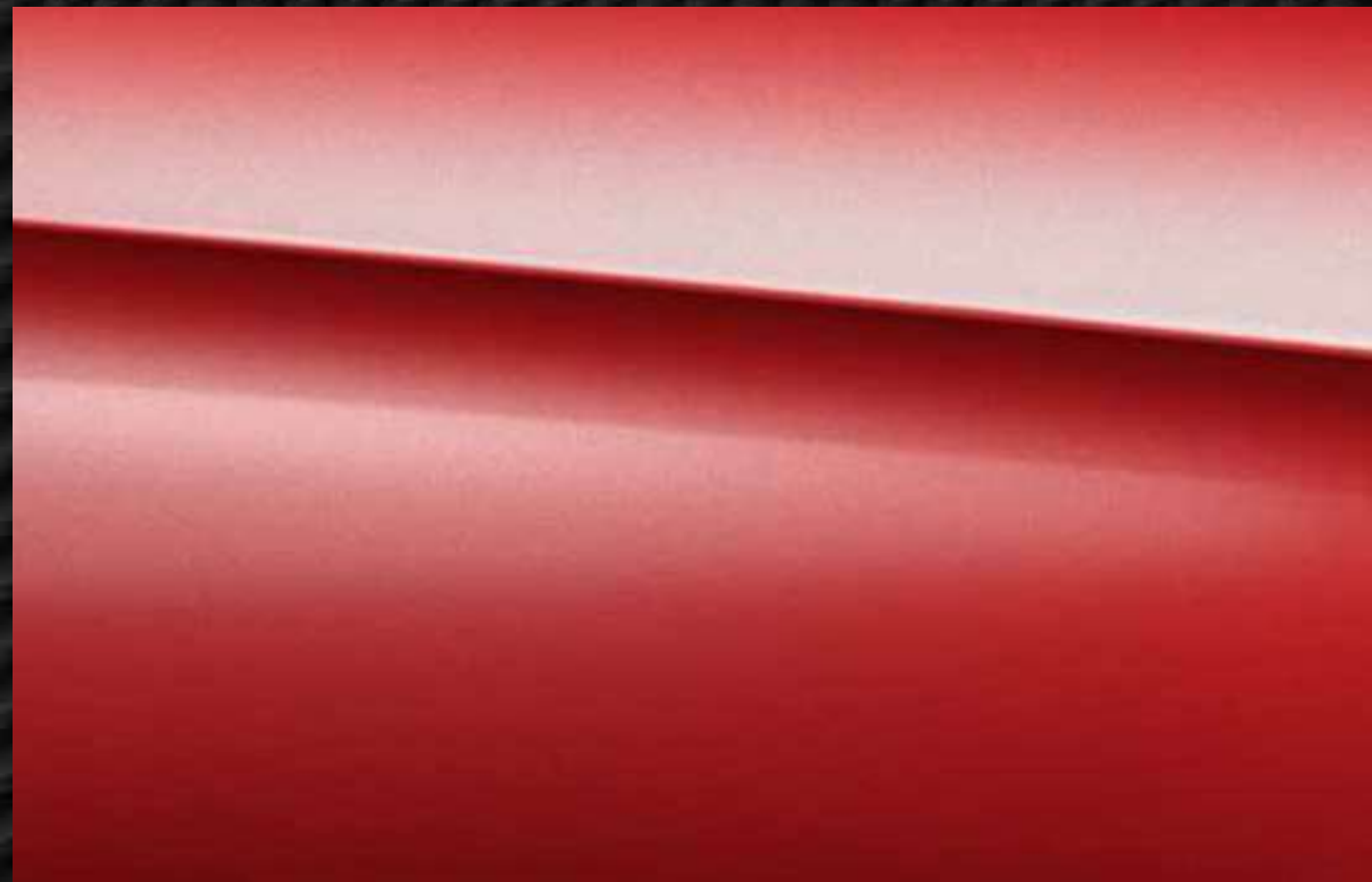
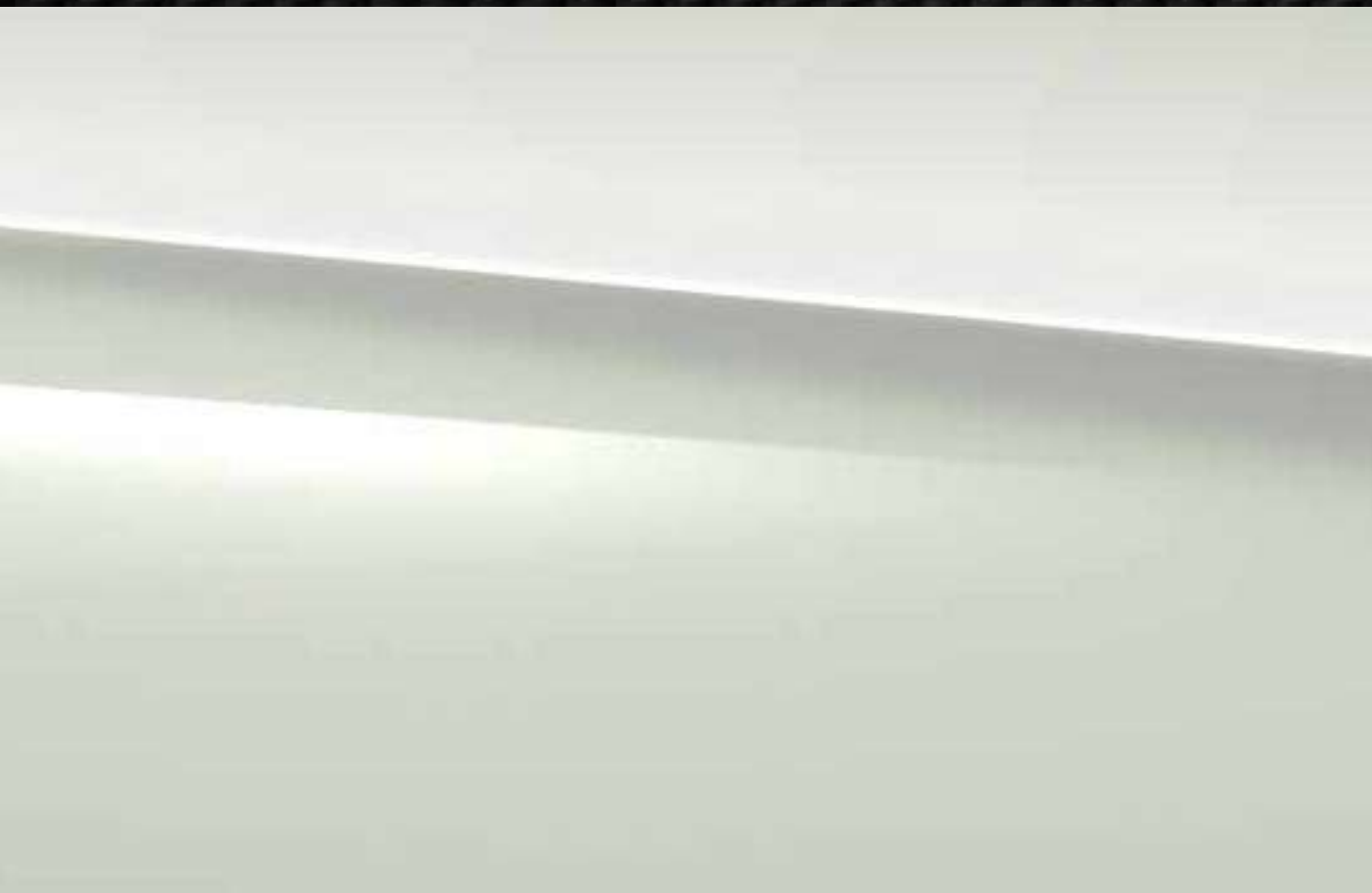

Polar White

Hyacinth Red

Metallic

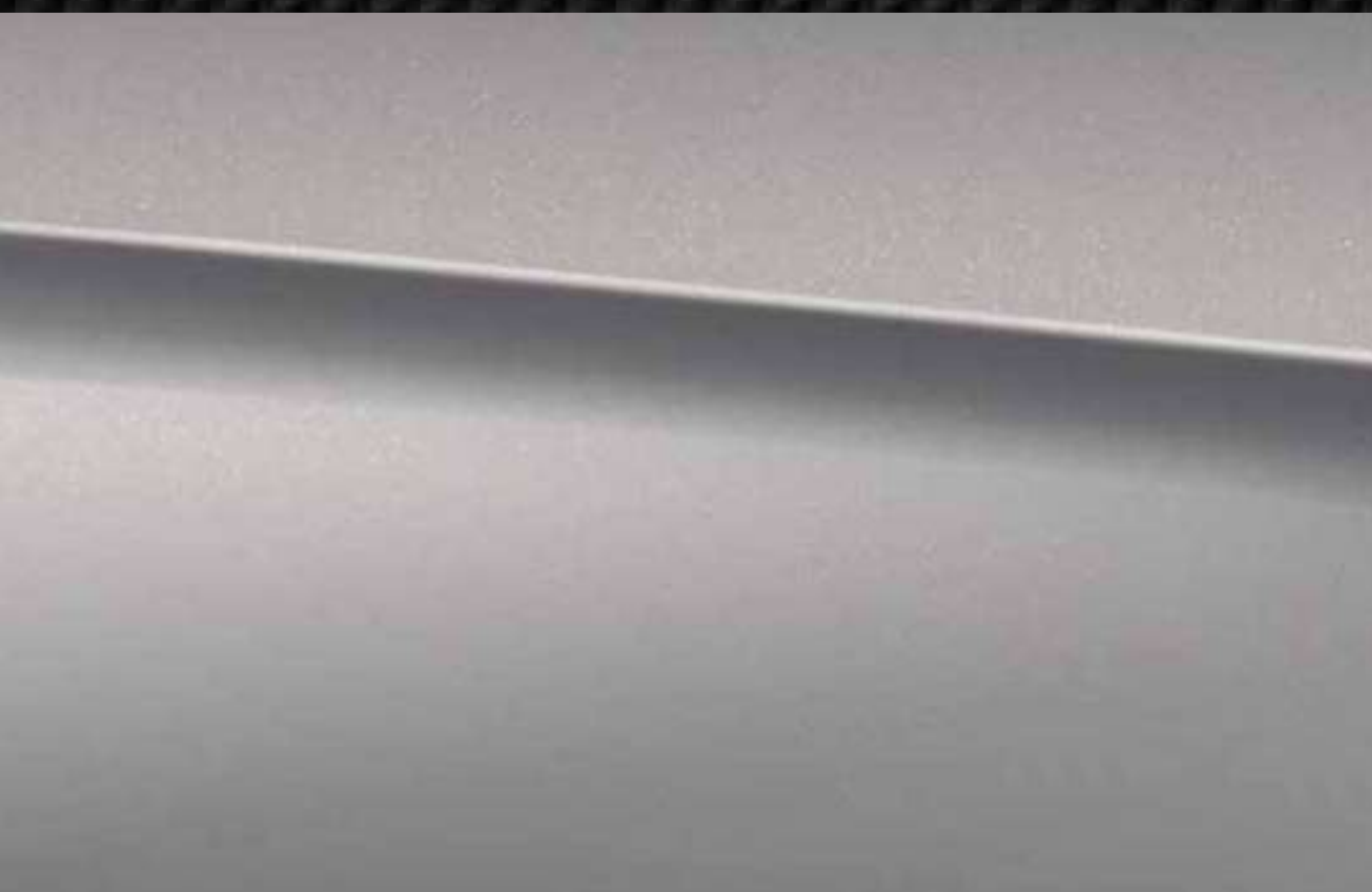

Mojave Silver

Cavansite Blue

# Paintwork

## Metallic

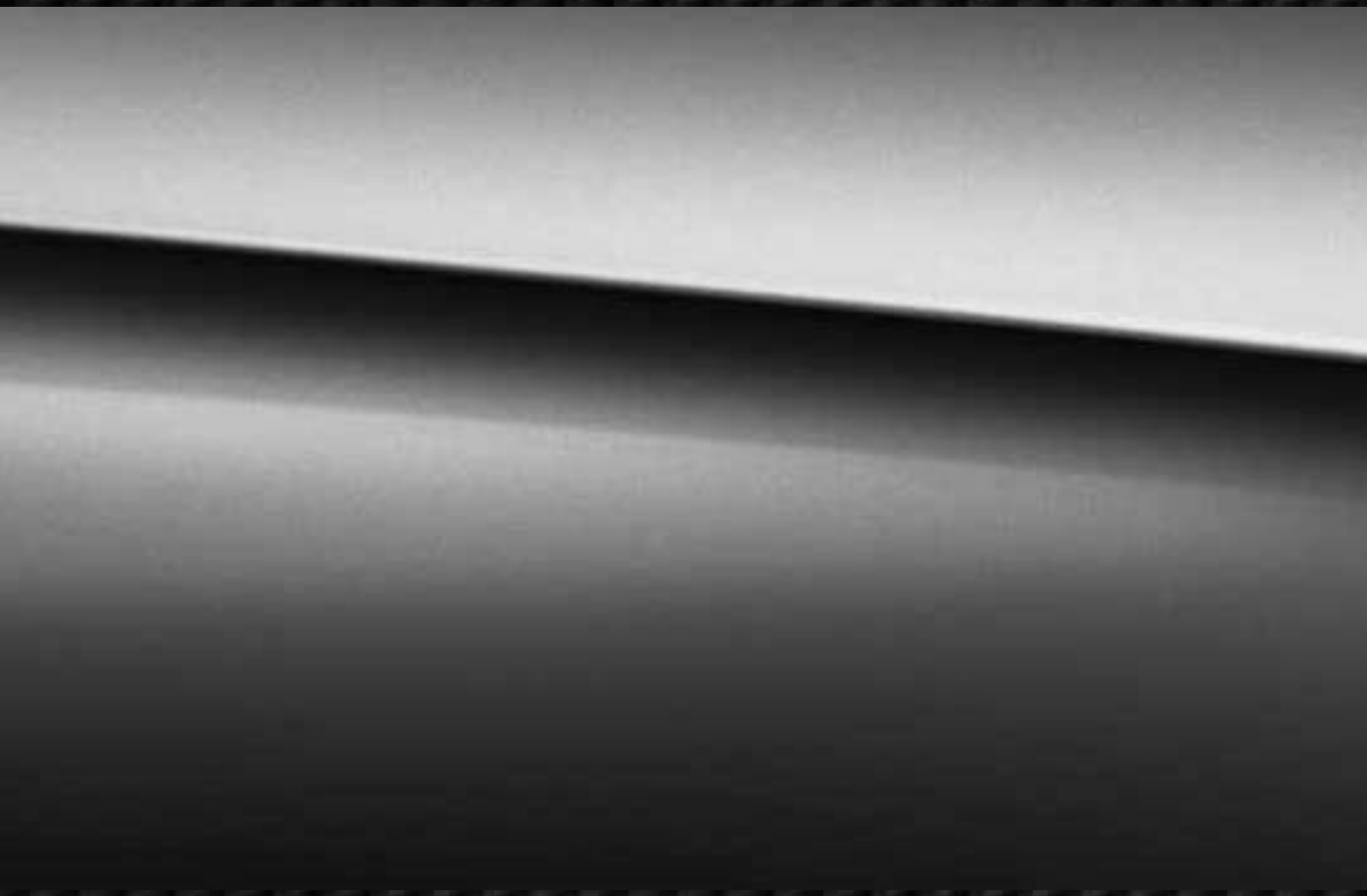

Obsidian Black

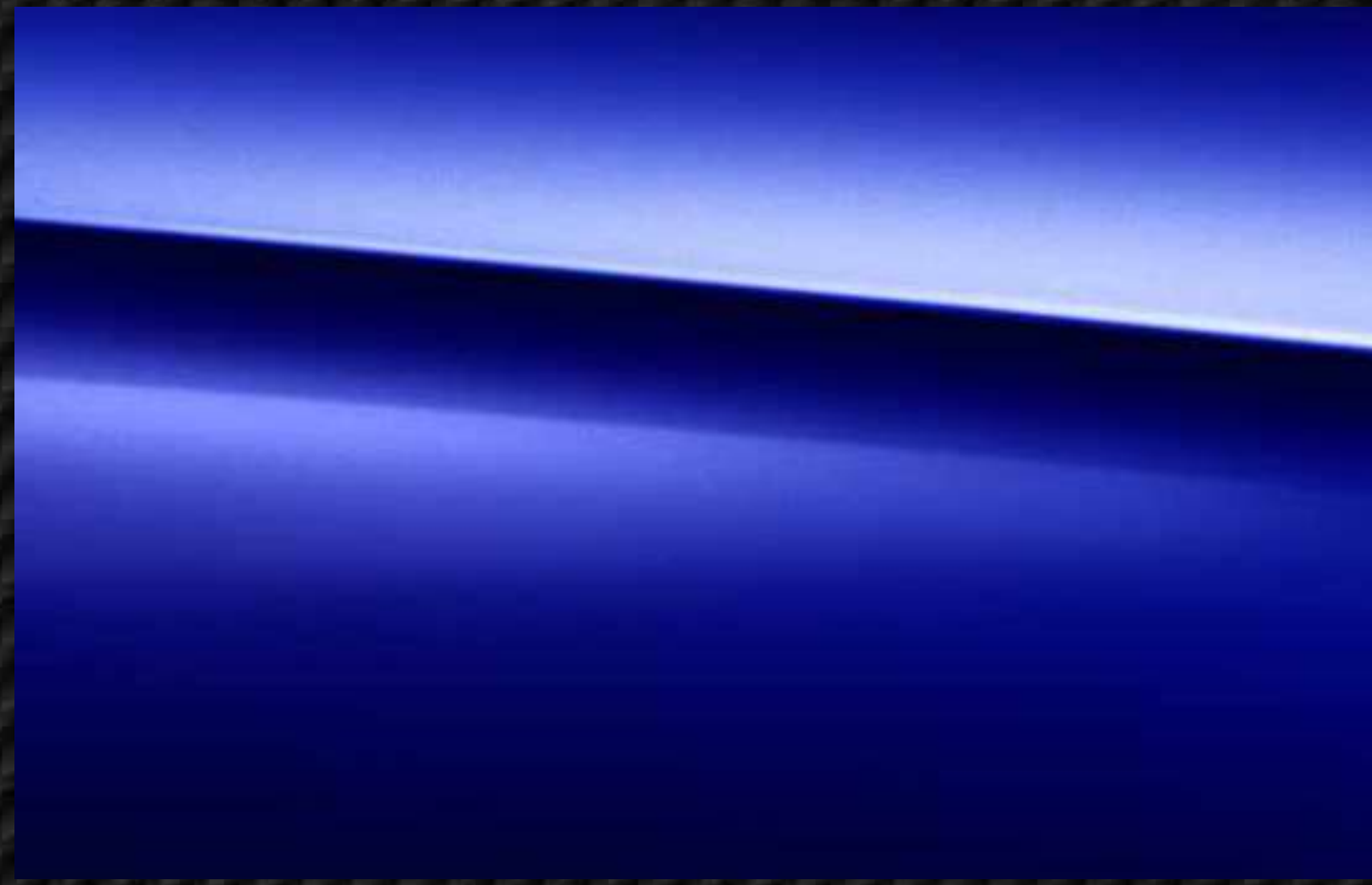

Brilliant Blue

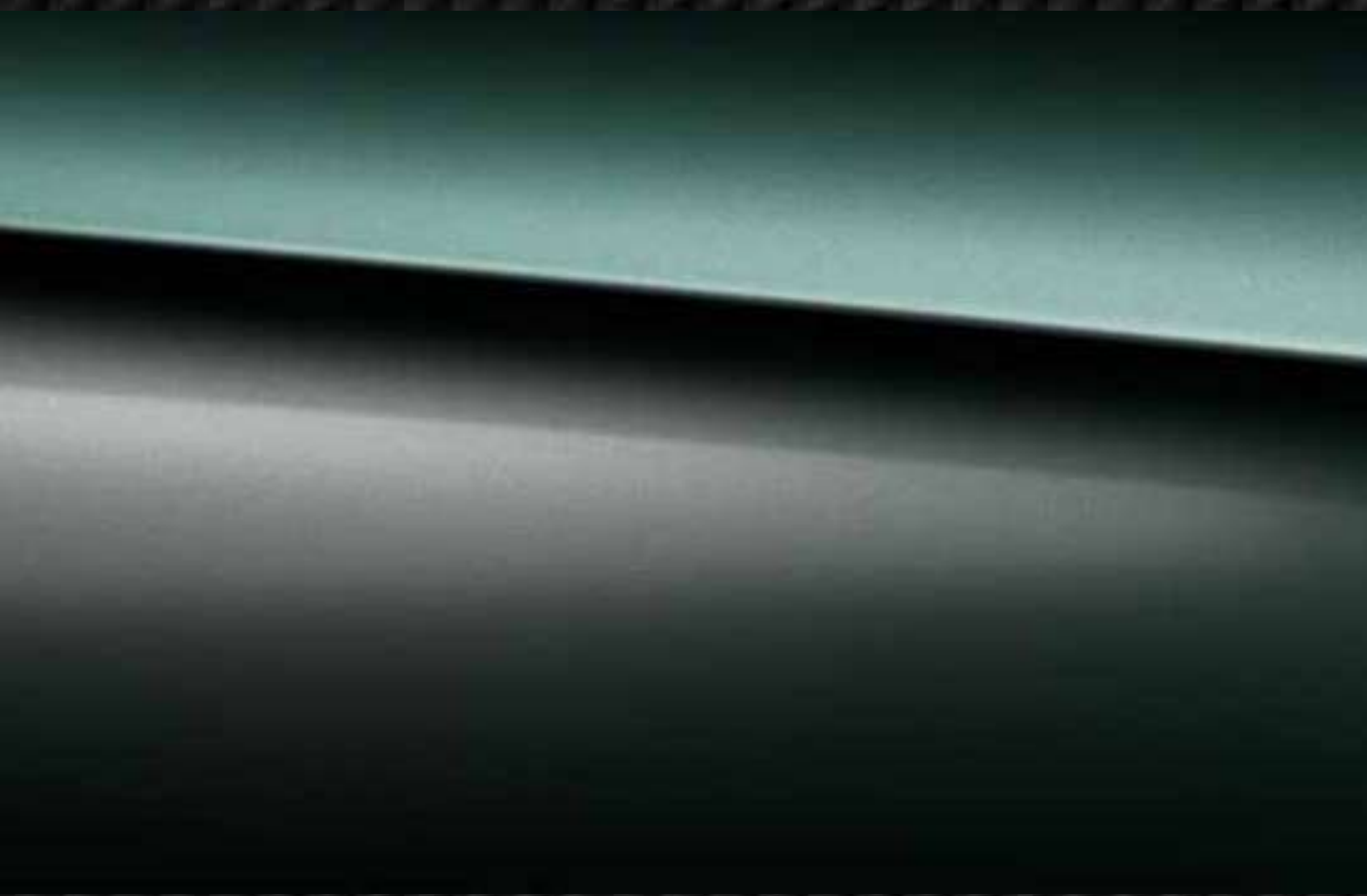

Emerald Green

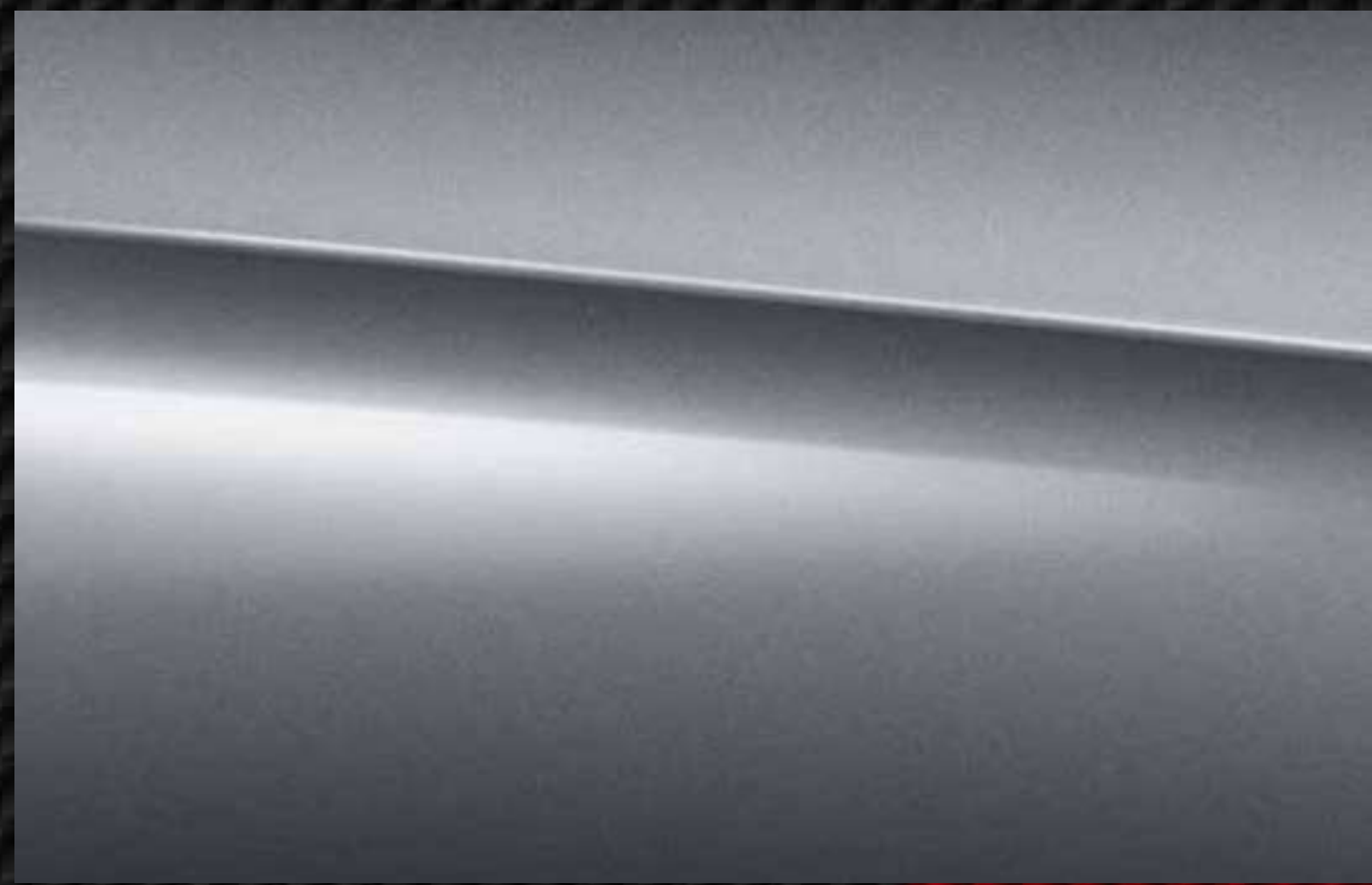

Selenite Grey

# Dimensions

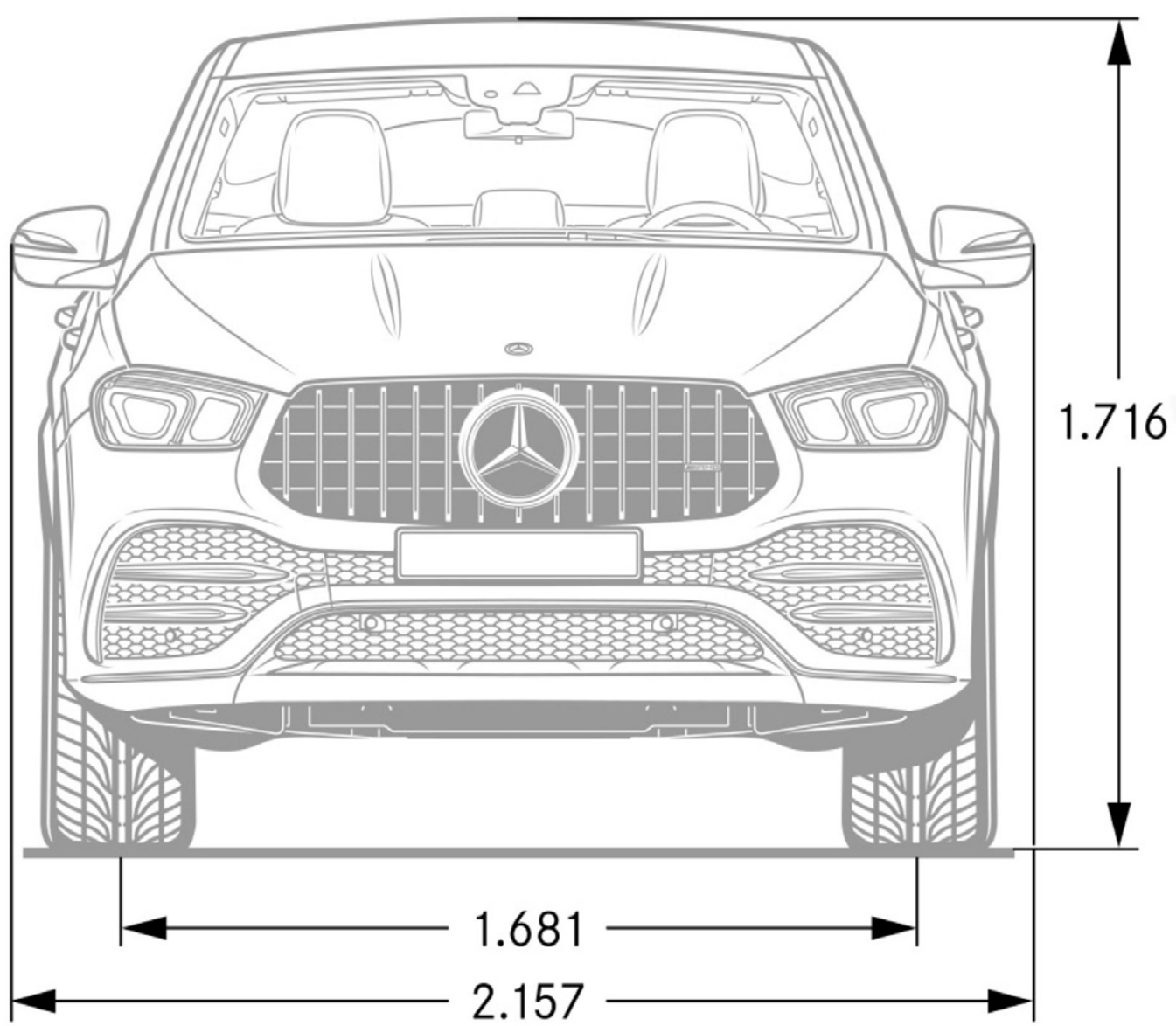

Front

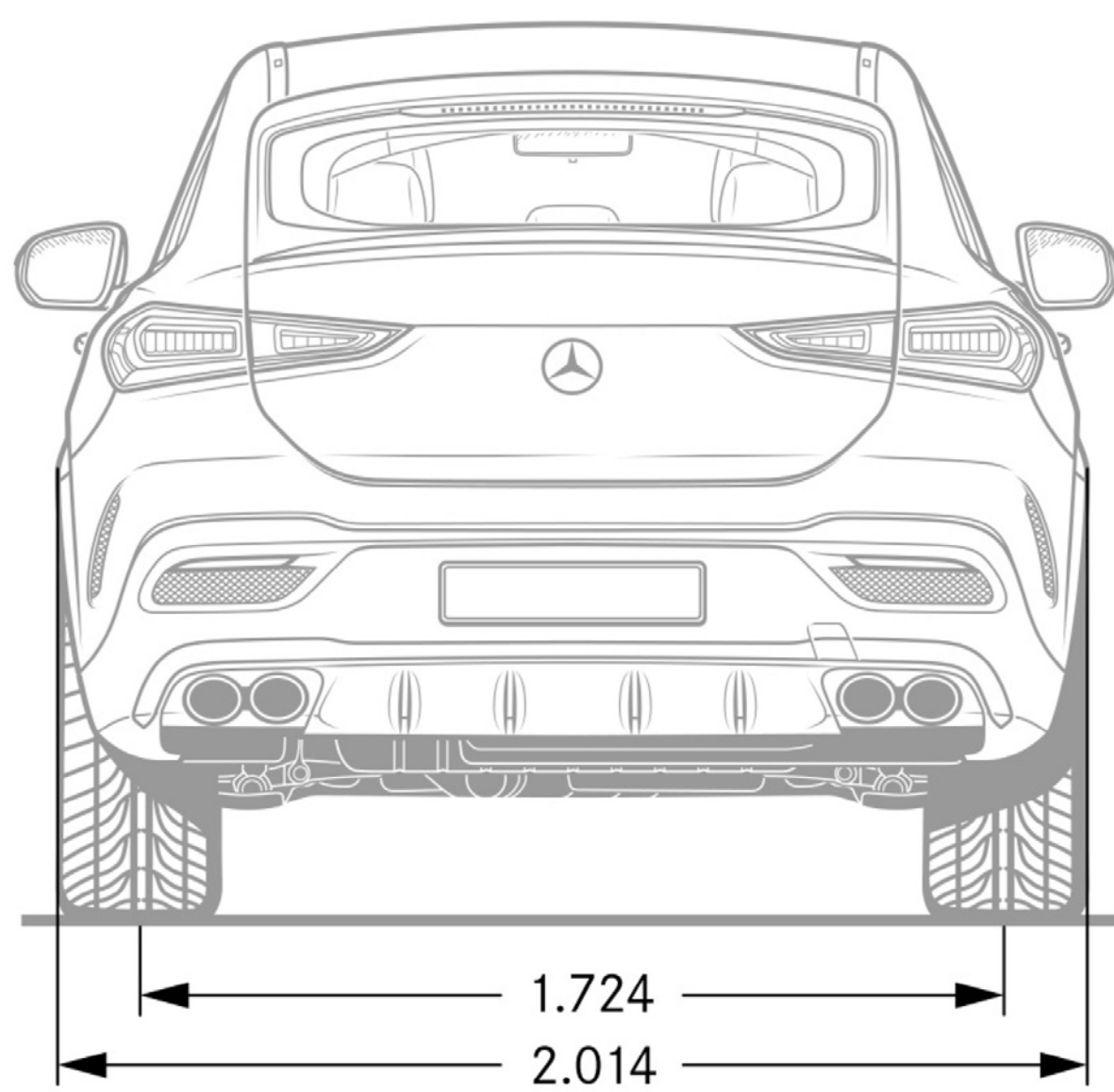

Back

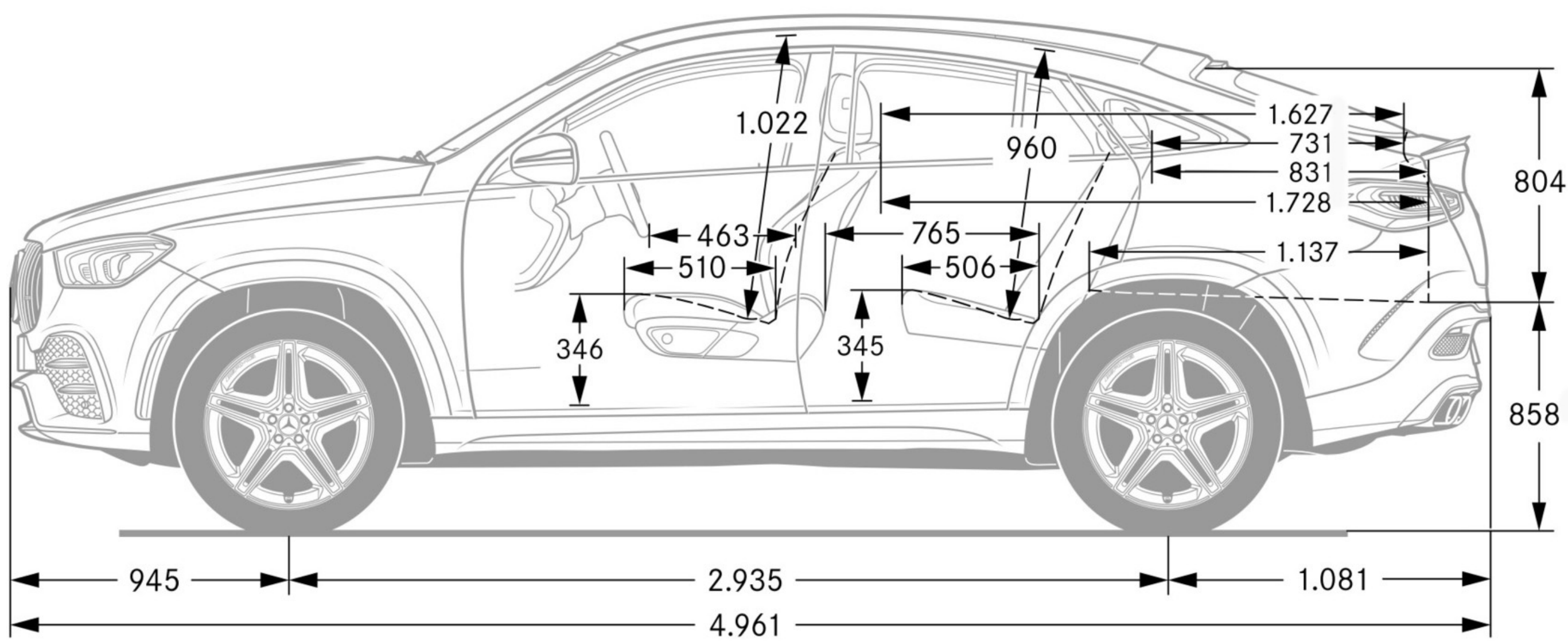

Side

# Technical Highlights

## TECHNICAL SPECIFICATION

## Mercedes-AMG GLE 53 4MATIC+ Coupé

Total displacement/No./  
arrangement of cylinders

2999 cc/L6

Rated output in kW (hp) @ rpm

320 [435] @ 5500 - 6100

Rated torque (Nm @ rpm)

520 @ 1800 - 5800

Transmission

AMG Speedshift 9G TCT Automatic

On-board Electrical System

48 V

Acceleration from 0 – 100 km/h (sec)

5.3

Top speed approx. (km/h)

250

Maximum gross weight (Kg)

3050

L x W x H (mm)

4961 x 2014 x 1716

Fuel Tank Capacity (L)

85

# Genuine Accessories

Make your Mercedes-AMG GLE 53 4MATIC+ Coupé even more promising with Genuine Accessories. Additional charges apply.

## Coolbox



The multifunctional coolbox cools or warms according to your needs. It cools to as low as  $-2^{\circ}\text{C}$ .

## Travel and Style Coat Hanger



For crease-free clothes when you're on the move, the sturdy coat hanger allows you to hang up items of clothing on board.

## Concertina load sill protector



The concertina load sill protector not only protects the boot from contamination, but also protects the bumper and boot sill from getting scratched. As the mat can be folded out, even your clothes stay clean when loading the boot.

## DUO plus child seat, with ISOFIX

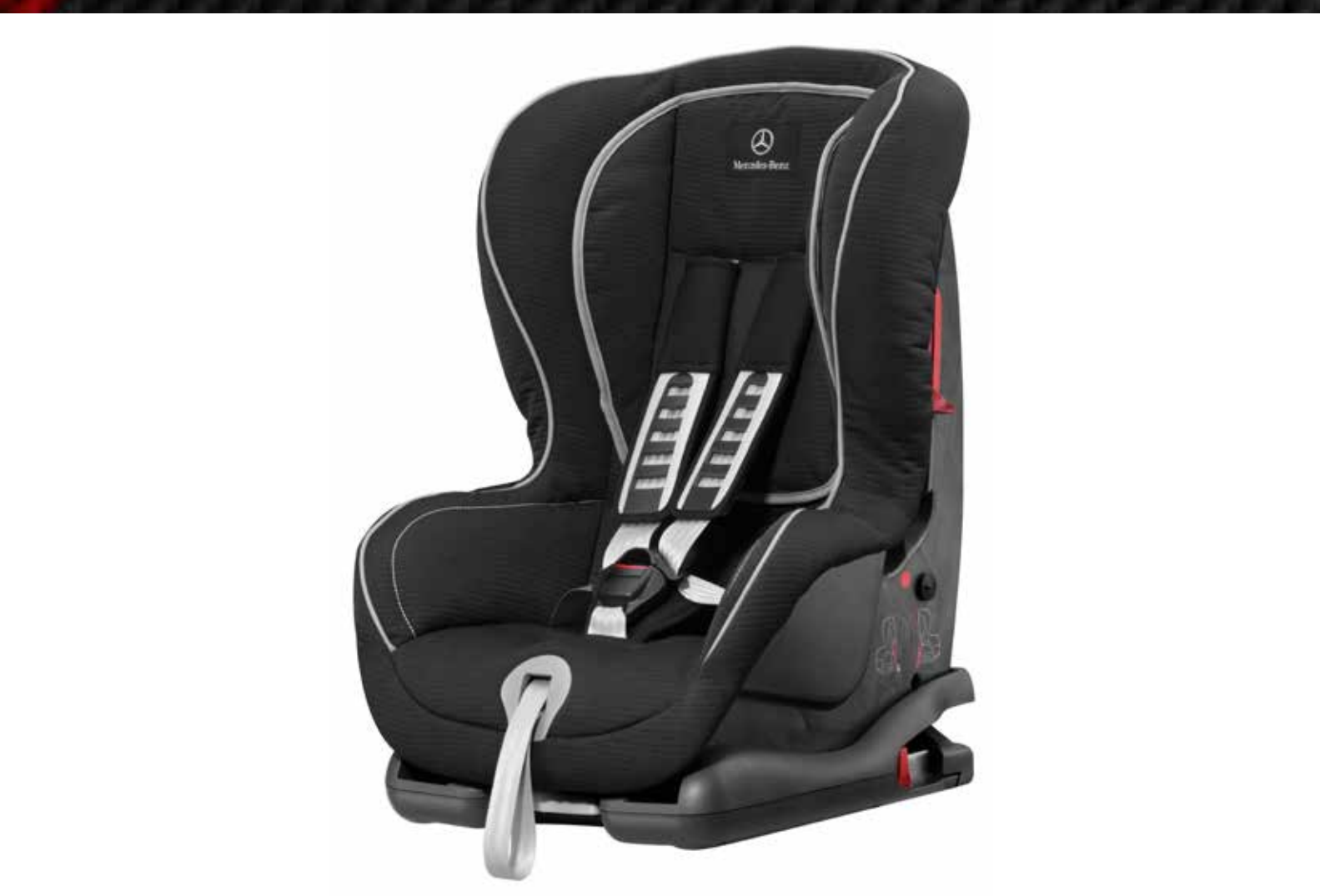

Children from the age of around 9 months to 4 years (weight 9 to 18 kg) will enjoy travelling in the "DUO plus" child seat. The seat offers optimum protection in the event of a mishap. Sitting reclining and sleeping positions are adjustable with one simple manoeuvre. The harness height is easy to adjust in 7-stages.

## Folding table, Style & Travel Equipment



A practical place to put snacks and drinks during the journey. The folding table with direct adapter features a cup holder insert. Direct adapter makes it easy to secure the table in place.

## Alloys



53.3 cm (21-inch)  
AMG 5-twin-spoke wheel,  
painted in Titanium Grey  
high-sheen



53.3 cm (21-inch)  
AMG 5-twin spoke wheel,  
painted in Matt Black  
high-sheen



53.3 cm (21-inch),  
6-twin-spoke wheel,  
painted in  
high-sheen Black

**Mercedes-Benz India Private Limited:** E-3, MIDC Chakan - Phase III, Chakan Industrial Area, Kuruli & Nighoje, Tal: Khed, Pune - 410 501 (India) Toll free No.: 0008000501888.  
e-mail: cs.ind@cac.mercedes-benz.com, **website: [www.mercedes-benz.co.in](http://www.mercedes-benz.co.in)**

**Please note:** This brochure is intended for general information, description and illustration of the Product including optional functions and equipment and may not be specific to a Product since specification of a product may change from time to time. Optional features, functions and equipment etc. may not be present in the Standard or Variant Product or Special Edition Product. Further, Standard specifications of a product may also vary from time to time. Colours may differ from those shown in pictures in the brochure. Mercedes-Benz India reserves the right to make changes without prior notice, in design, colours, materials, components, equipment, specifications, features, functions, make and models etc. The information given in this brochure shall be regarded as accurate at the time of launch and may vary thereafter due to any developments or any other reason. Interested customers should reach out to the Authorised Franchise Partner for further information on the exact specifications, features of the product.

Images shown are for representation purposes only. Some of the vehicles in the Brochure are left hand drive wheel. However, Mercedes-Benz India only manufactures and sells vehicles as per the applicable motor vehicle regulations in India. All vehicles sold by Mercedes-Benz Authorized Franchise Partners shall be with right hand drive wheels only.

All title, ownership rights and intellectual property rights in and relating to this brochure/magazine or publication material or any copies thereof including but not limited to copyright, logos, names, trademarks, service marks, design, text, images, links, concepts and themes are owned by Daimler AG and/or its subsidiaries collectively or used under authorised license by the Daimler AG. Any reproduction, transmission, publication, performance, broadcast, alteration, license, creation of derivative works or other use in whole or in part in any manner without the prior written consent of Mercedes-Benz India Pvt. Ltd is strictly prohibited.

Please note that certain services are offered free of cost for a period of three (03) years and may be chargeable at the expiry of three (03) years from the date of activation of such services. If you wish to continue using those services, you may renew the same through Mercedes Me Store (as and when it is available). Please get in touch with your preferred Franchise Partner for more details.

Mercedes-Benz cars: The AMG GLE 53 4MATIC+ Coupé meets Bharat Stage VI equivalent emission norms.

CIN - U34102PN1994PTC083160