

THE NEW GS







THE NEW GS

Introduction	04 - 07
Driving Dynamics	08 - 09
Design	10 - 11
Interior Luxury	12 - 15
Multimedia	16 - 17
Full Hybrid	18 - 23
F SPORT	24 - 25
Advanced Technology	26 - 27
Innovative Safety	28 - 29
Lexus Quality	30 - 31
Environmental Leadership	32 - 33
Technology & Specifications	34 - 67



"THE NEW GS REPRESENTS A POWERFUL CHANGE. TAKE, FOR EXAMPLE, THE BOLD 'SPINDLE GRILLE' OR ENGINEERING BREAKTHROUGHS LIKE LEXUS DYNAMIC HANDLING AND SECOND-GENERATION LEXUS HYBRID DRIVE."

Yoshihiko Kanamori, GS Chief Engineer

AMAZING IN MOTION

Developing the all-new GS Full Hybrids involved relentless efforts to make it better in every way. With world-class quality overseen by Lexus 'Takumi' craftspeople, the GS resets benchmarks for comfort, sophistication and advanced technology. Inside, the driver's seat took five years to perfect, there are also award-winning nanoe[®] air conditioning and innovative driver support systems. However, most important of all, the new GS is incredibly enjoyable to drive. To achieve this, prototypes were tested over 1.6 million kilometres; proving - quite literally - that we don't stop until we create amazing.

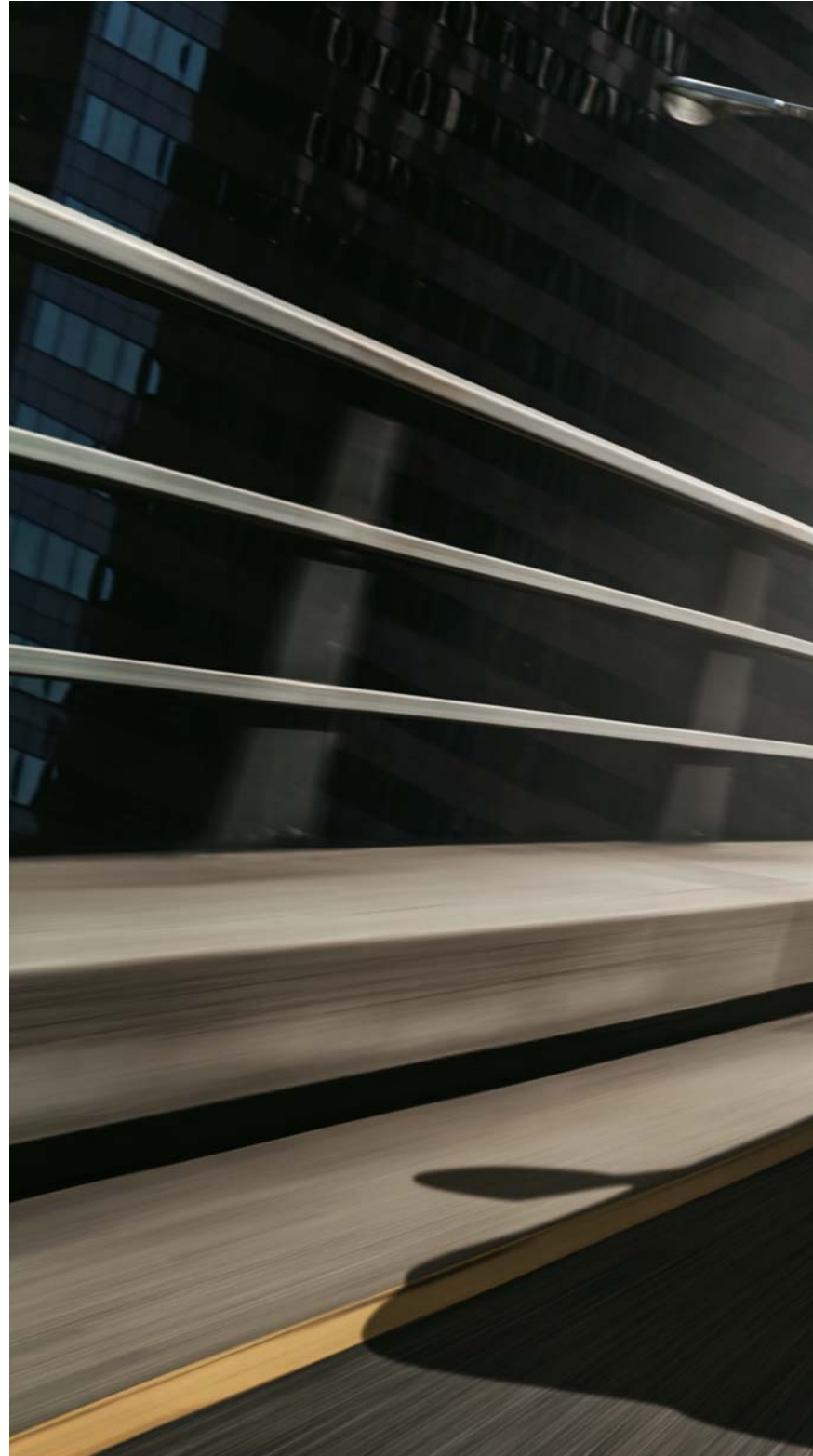



THE NEW GS INTRODUCTION

A DYNAMIC CHANGE

LEXUS HYBRID DRIVE IN THE GS 300h AND
GS 450h, BOTH AVAILABLE AS F SPORT MODELS.



The new range of GS sedans offers you a choice of two amazing Full Hybrid drivetrains: a 3.5-litre, V6 hybrid in the GS 450h that will power you from 0-100 km/h in just 5.9 seconds up to a top speed of 250 km/h (where permitted), or a highly efficient 2.5-litre hybrid unit in the GS 300h that delivers incredibly low emissions of just 104 g/km* of CO₂. Whichever GS you choose, each offers sharp, precise steering and excellent control when cornering, and are both available as dynamic F SPORT models.

* For the Eco grade equipped with 17" alloy wheels.







THE NEW GS

DRIVING DYNAMICS

A NEW KIND OF LEXUS

TESTED OVER 1.6 MILLION KILOMETRES, YOU'LL ENJOY THE DYNAMIC HANDLING AND WORLD-CLASS REFINEMENT OF THE NEW GS.

The GS is a totally new kind of Lexus sedan - one that was developed in the world's most advanced driving simulator, and then tested over 1.6 million kilometres. We started by increasing the chassis rigidity, fitting new dampers and engineering a new rear multi-link suspension. We then created a sophisticated aerodynamic concept that moves airflow closer to the vehicle body, to boost dynamic performance and steering precision. Enhancing the car's class-leading refinement even further, smooth underbody covers and fins on the rear lights increase stability and reduce wind noise.

ARRIVE WITH PRESENCE

THE NEW GS FEATURES A BOLDER 'SPINDLE GRILLE' FLANKED BY TRIPLE LED 'L'-SHAPED HEADLIGHTS.

Our designers have given the GS a totally new look, the focal point being its dramatic Lexus-signature 'spindle grille'. Striking new triple 'L'-shaped headlights enhance the front styling and use the same LED light source for both high and low beam. The headlights are also underscored by 'L'-shaped Daytime Running Lights. In profile, the car's muscular stance contrasts its lean waistline and long, streamlined cabin section to create unique presence and exceptional roominess for up to five occupants and their luggage. To the rear, LED lights round off this powerful sedan with crystal-like illumination.

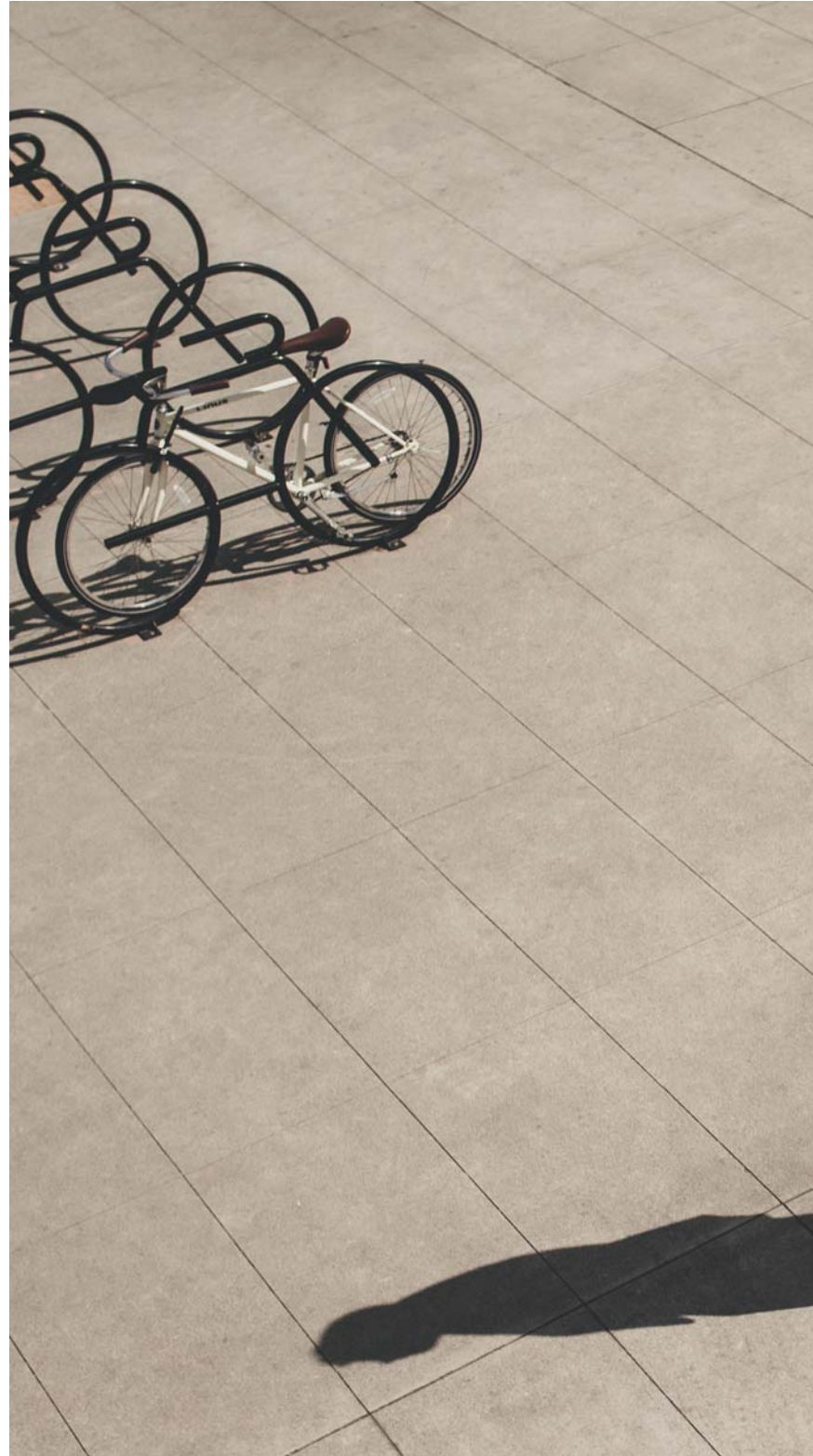











THE NEW GS INTERIOR LUXURY

AN EXCLUSIVE LOCATION

RELAX IN 18-WAY LEATHER SEATS THAT TOOK 5 YEARS TO PERFECT, IN A LUXURIOUS CABIN BUILT BY 'TAKUMI' MASTER CRAFTSPEOPLE.

The new GS's driver-focused cockpit will keep you perfectly relaxed, even on the longest journeys. Behind the beautifully crafted steering wheel, the quilted front seats - that took five years to perfect - offer up to 18-way electric adjustments. The front seat passenger can also enjoy the luxury of an electrically extending seat cushion. Using Remote Touch, you can intuitively navigate or enjoy the 17-speaker Mark Levinson® audio. Attention to detail is everywhere: witness exquisite stitching and a precision-engineered LED analogue clock that forms a centrepiece of the dashboard. Using GPS, this even resets itself should you enter a new timezone.

ENHANCED VISION

INTERACT WITH THE LARGE 12.3-INCH MULTIMEDIA DISPLAY, USING THE LATEST REMOTE TOUCH CONTROLLER.

To make driving more enjoyable, our interior designers strived to simplify life in the new GS. Positioned unobtrusively in your field of vision, key information is projected via a colour Head-Up Display onto the windscreen, or presented on a multi-information display between the main instruments. Audio, climate and navigation systems are all accessed on the central 12.3-inch, full colour LED screen. The size and absolute clarity of this allow you to display a full screen map, or two types of information simultaneously, such as map/audio and navigation input or incoming call.









GS 300h



THE NEW GS 300h DELIVERS 223 DIN hp OF FULL HYBRID POWER, YET EMITS JUST 104 g/km* OF CO₂.

The GS 300h is powered by second-generation Lexus Hybrid Drive. This intelligently combines an advanced 2.5-litre direct-injection petrol engine with a high-output electric motor, while innovative Active Sound Control delivers a sophisticated engine note. The GS 300h is fun to drive, yet consumes a mere 4.4 l/100 km*. Select Electric Vehicle mode to progress in near silence, using no petrol and producing zero emissions. There's plenty of luggage space too and, thanks to our leadership in hybrid technology, the GS 300h has the lowest running costs in its class.

* For the Eco grade.









THE NEW GS FULL HYBRID

GS 450h



DISCOVER BREATHTAKING ACCELERATION AND HIGH-SPEED PERFORMANCE IN THE WORLD'S MOST CAPABLE FULL HYBRID SEDAN.

The new GS 450h delivers amazing Full Hybrid performance, thanks to its powerful Lexus Hybrid Drive. Comprising a 3.5-litre V6 direct-injection Atkinson Cycle petrol engine and a high-output electric motor, it develops 345 DIN hp of power. Acceleration is both smooth and incredibly rapid (100 km/h in 5.9 seconds) yet fuel consumption has been reduced by more than 20% to 5.9 l/100 km*, and CO₂ emissions are only 137 g/km*. In common with all Lexus hybrids, in Electric Vehicle mode it uses no petrol and produces zero emissions.

* For the Eco grade.

DYNAMIC ATTRACTION

**THE NEW GS F SPORT MODELS FEATURE
AGGRESSIVE STYLING AND 19-INCH ALLOYS
WITH LARGE 356 MM BRAKES.**

Developed at the Nürburgring, by the team that perfected our LFA V10 supercar, the new GS F SPORT models offer an incredibly precise and exciting drive. Aggressive F SPORT front-end styling - that integrates upper and lower honeycomb grilles - gives an unmistakably dynamic look. The cockpit features a 16-way sports driver's seat; aluminium pedals, inlay panels and scuff plates; with the steering wheel and gearshift finished in perforated leather. For even more thrilling performance, the GS 450h F SPORT has breakthrough 'Lexus Dynamic Handling'.







PURE RELAXATION

STAY FRESHER WITH NANO^E® CLIMATE TECHNOLOGY, WHILE ENJOYING THE 17-SPEAKER MARK LEVINSON[®] AUDIO.

Yet another breakthrough on the new GS sedan is nano^E® climate technology. This releases microscopic particles into the cabin that deodorise upholstery and moisturise your skin and hair. Powerful yet very energy efficient, the sedan's intelligent 3-zone S-Flow air conditioning only controls the climate of those seats that are occupied. The GS is also the perfect place to enjoy the world-class 17-speaker Mark Levinson[®] Premium Audio system that provides a live concert experience when listening to music or watching DVDs.



PROGRESS WITH CONFIDENCE

LEXUS SAFETY SYSTEM + USES MILLIMETRE-WAVE RADAR AND A CAMERA TO DETECT DANGER AHEAD.

Lexus has always spearheaded the development of safety and driver support technologies, and tests all new models in the world's largest driving simulator. Benefitting from our lead in accident prevention research, the new GS can be fitted with the breakthrough Lexus Safety System +. This includes a Pre-Crash System with pedestrian detection; Advanced Lane Keeping Assist with Sway Warning function to help you stay on course; Road Sign Assist that presents traffic sign information to the driver; Automatic High Beam or Adaptive High-beam System for enhanced vision at night; and Adaptive Cruise Control, which regulates your speed to that of the vehicle in front.







TAKUMI CRAFTSMANSHIP

PRODUCTION IS OVERSEEN BY 'TAKUMI' MASTER CRAFTSPEOPLE, WHO ALSO INSPECT EACH GS BEFORE THE FINAL 30 KM TEST DRIVE.

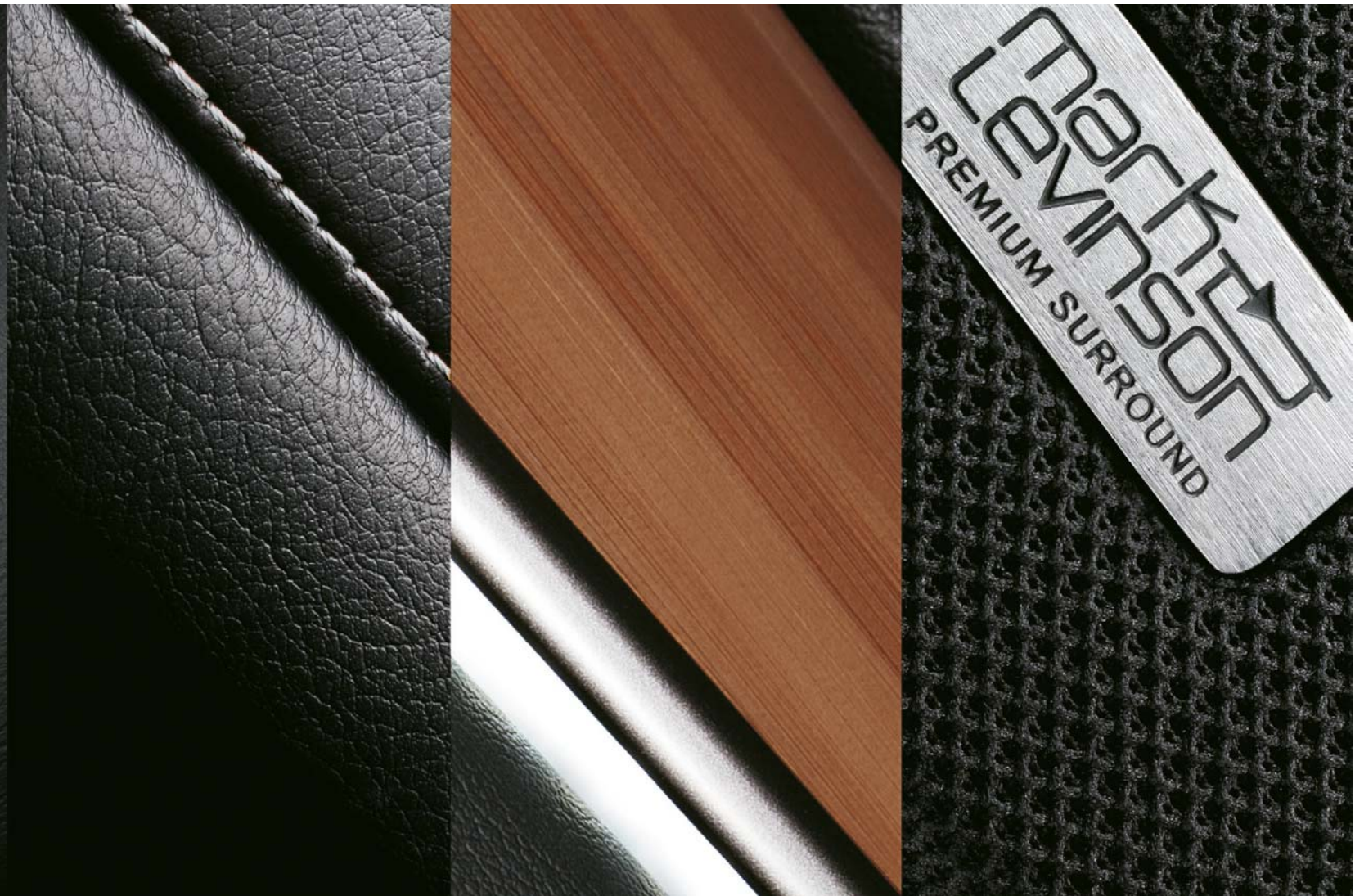

You'll sense the amazing quality of the new GS when you first touch the beautifully stitched leather steering wheel or precision-machined aluminium audio controls. The car's gleaming paintwork is wet sanded by hand (a time-consuming process normally reserved for coach-built cars) and checked by eye as well as digitally to ensure a perfect finish. Manufactured at the plant that built our iconic Lexus LFA supercar, GS production is overseen by Lexus 'Takumi' personnel. These highly trained master craftspeople rigorously check that every car meets our peerless quality standards.

ECO LEADER

AVAILABLE WITH INNOVATIVE FULL HYBRID DRIVETRAINS, ECO AIR CONDITIONING AND LOW ENERGY LED LIGHTS.

Everything about the new GS is designed to minimise environmental impact: advanced Full Hybrid drivetrains, highly efficient S-Flow air conditioning, GreenEdge™ audio technology and a bio-sourced bamboo for the steering wheel. At the end of its life, up to 85% of the car can be recycled, including the hybrid battery. Production is organised using our world-famous lean manufacturing techniques, with waste being kept to an absolute minimum, while every day our Aqua Control Centre purifies thousands of tons of water.







TECHNOLOGY & SPECIFICATIONS

Lexus Hybrid Drive	36 - 39
Driving Dynamics	40 - 41
Advanced Safety	42 - 43
Exterior Features	44 - 45
Interior Features	46 - 47
Audio and Multimedia	48 - 49
F SPORT	50 - 51
Technical Data	52 - 53
Standard / Additional Equipment	54 - 55
Options and Packs	56 - 57
Accessories	58 - 59
Interior Combinations	60 - 63
Exterior Colours	64 - 65
Lexus Care	66 - 67



FULL HYBRID TECHNOLOGY

In 2004, Lexus became the first premium carmaker to perfect Full Hybrid technology. Since then, close to one million Lexus hybrid models have been sold. The second-generation Lexus Hybrid Drives fitted to the new GS 300h and GS 450h deliver refined power with outstanding fuel efficiency and exceptionally low emissions - zero when in EV (Electric Vehicle) mode. More information: www.lexus.eu/hybrid





'ATKINSON CYCLE' PETROL ENGINE

Equipped with innovative D-4S direct injection and dual VVT-i technology, a highly efficient 'Atkinson Cycle' engine is at the heart of the GS 300h (2.5-litre, 4-cylinder) and GS 450h (3.5-litre, V6). Also featuring Start/Stop, these breakthrough powertrains help reduce fuel consumption and emissions even further.

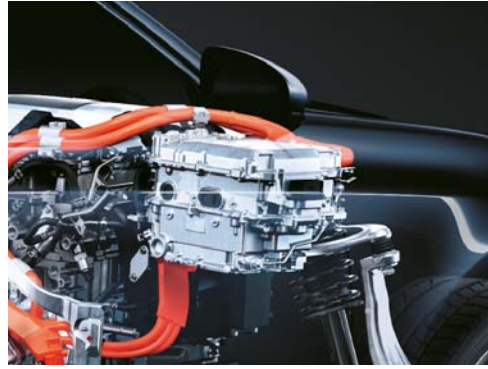

POWER CONTROL UNIT

The 'brain' of Lexus Hybrid Drive, the Power Control Unit (PCU) constantly optimises the allocation of power resources – electric, petrol or a combination of both. The PCU also manages the process of charging the hybrid battery, either by allocating engine power to drive the generator or through regenerative braking.



ADVANCED HYBRID BATTERY

Energy-management of the nickel-metal hydride battery is controlled by sophisticated software. This ensures the battery is recharged as necessary during driving, so that external charging is never required. The compact design contributes to significantly increased boot capacity.



REGENERATIVE BRAKING

When braking or decelerating, the vehicle's wheels drive the high-output electric motor so that it functions as a generator. Kinetic energy – which would otherwise be lost as heat – is then captured and converted into electric power. This is stored in the hybrid battery for later use when driving in Electric Vehicle mode or accelerating swiftly.

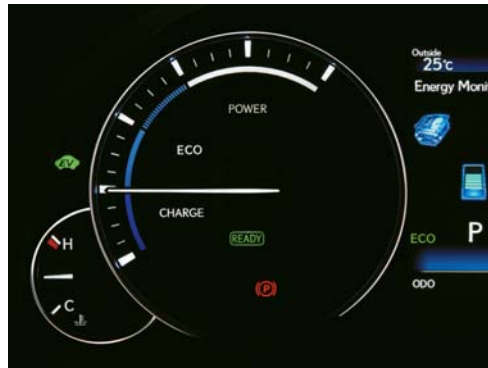

ELECTRIC VEHICLE (EV) MODE

With sufficient battery charge, EV mode lets you drive at lower speeds over shorter distances using just electric power. EV mode is whisper quiet, emissions-free and consumes no fuel. This is ideal, for instance, when driving in slow-moving traffic or enclosed car parks.



FULL HYBRID PERFORMANCE

The new GS 300h and GS 450h deliver impressive Full Hybrid performance. You can accelerate from 0 to 100 km/h in just 5.9 seconds in the GS 450h (up to 250 km/h where permitted) while, overall, combined emissions of the GS 300h are just 104 g/km* and fuel consumption is only 4.4 l/100 km*.

* For the Eco grade.

EXPERIENCE LEXUS HYBRID DRIVE



START UP, DRIVING OFF

When starting off, the powerful electric motor can swiftly propel the GS 300h or GS 450h up to 64 km/h, with electric power supplied by the hybrid battery. At this point the vehicle is almost silent, uses no petrol and produces zero emissions.



NORMAL DRIVING CONDITIONS

At speeds above 64 km/h the ultra-smooth direct-injection Atkinson Cycle petrol engine cuts in, almost silently, but still receives assistance from the electric motor when required. Through the near perfect distribution of its petrol and electric power sources, the GS 300h and GS 450h provide extraordinary driving excitement - together with low emissions and modest fuel consumption.



FULL THROTTLE ACCELERATION

Accelerate powerfully and the electric motor instantaneously supplements the petrol engine. Together they deliver a potent surge of torque to provide linear acceleration precisely when you need it.



DECELERATION, STOPPING, BRAKING

When decelerating or coming to a halt, the petrol engine turns off, cutting emissions to zero. Brake, or take your foot off the accelerator, and regenerative braking harnesses the kinetic energy lost in other cars. It converts this into electrical energy for storage in the hybrid battery, which is one reason why you never need to recharge a Lexus Full Hybrid.

DRIVING DYNAMICS

The new GS was developed in the world's most advanced driving simulator - and then driven 1.6 million kilometres around the globe. GS Chief Engineer Yoshihiko Kanamori personally tested this rear-wheel drive performance sedan on the Nürburgring in his relentless pursuit of enhanced driving enjoyment and precision.



FRONT SUSPENSION

Featuring forged aluminium components and a revised design, the double wishbone front suspension is now lighter and more responsive. Extensive adjustments to the suspension structure have substantially improved handling stability and ride comfort.



REAR SUSPENSION

Straight-line and cornering stability are significantly enhanced by geometry and layout revisions to the multi-link rear suspension. A combination of high-tensile steel, die-cast and forged aluminium components reduce weight yet increase strength and precision.

CHASSIS

With greater torsional rigidity and redesigned suspension, the new GS is dynamic and engaging to drive. It is a car that conveys a tangible sense of driver confidence, with a chassis that inspires and rewards driver input with crisp and precise handling.





■ ADAPTIVE VARIABLE SUSPENSION

The damping force at all four wheels is intelligently controlled by the Adaptive Variable Suspension in response to road surface conditions and driver input. This not only improves ride comfort, but also increases handling stability – especially during higher-speed cornering.

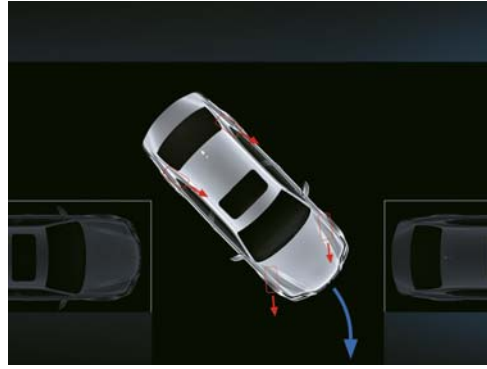

■ LEXUS DYNAMIC HANDLING

Exclusive to the new GS 450h F SPORT, Lexus Dynamic Handling elevates driving performance to a new dimension. Together, Variable Gear Ratio Steering and Dynamic Rear Steering control all four wheels independently. At low to medium speeds, the front and rear wheels turn at slightly opposing angles. This significantly reduces the turning circle for improved manoeuvrability at slow speeds, while improving agility when driving along winding country roads. At higher speeds, all four wheels steer in the same direction to enhance rear grip and stability. This ensures exceptionally composed lane changing and confident cornering at high speed.

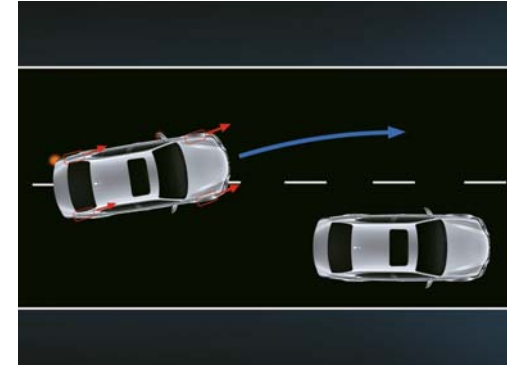

DRIVE MODE SELECT

Vehicle performance can be fine-tuned using Drive Mode Select. ECO mode reduces emissions and conserves fuel during relaxed driving, while NORMAL is configured for everyday driving – striking an ideal balance between economy and ride comfort. SPORT S immediately increases powertrain responsiveness for faster acceleration. With Adaptive Variable Suspension (AVS) specified, SPORT S+ intelligently controls the powertrain and AVS for exceptionally engaging performance. In the GS 450h F SPORT, 5-step Vehicle Dynamics Integrated Management also networks control of Lexus Dynamic Handling in SPORT S+ mode. The results are supreme levels of on-the-limit vehicle agility and control.

ADVANCED SAFETY

LEXUS SAFETY SYSTEM +



The new GS can now be ordered with our breakthrough Lexus Safety System + that combines Pre-Crash Safety, Adaptive Cruise Control, Advanced Lane Keeping Assist, Road Sign Assist and Automatic High Beam in one powerful package.



● PRE-CRASH SAFETY

Millimetre-wave radar and an on-board computer calculate collision risk ahead. If the risk is high, the driver is alerted by audible and visual warnings and brake pressure is increased. When a collision is deemed unavoidable, the brakes will be applied automatically as necessary and the front seatbelts tightened.

● PEDESTRIAN DETECTION

As part of the Pre-Crash Safety system, if an object (such as a pedestrian) is detected in front of the new GS, automatic braking will activate when the car is travelling between about 10 and 80 km/h to help avoid a collision.



● ADVANCED LANE KEEPING ASSIST

Advanced Lane Keeping Assist (A-LKA) uses a camera in the front windscreen to monitor your position in lane. If you start drifting out of lane, A-LKA will activate a warning buzzer and give brief corrective steering input.

● AUTOMATIC HIGH BEAM

At night, Automatic High Beam uses the same camera as Advanced Lane Keeping Assist to detect oncoming vehicles and automatically dip the high beam headlights. This reduces the chance of accidentally dazzling other drivers and lets you concentrate on the road ahead.



● ADAPTIVE CRUISE CONTROL

For a more relaxing drive, Adaptive Cruise Control maintains a set distance between the new GS and the vehicle ahead, even if that vehicle varies its speed.



● ROAD SIGN ASSIST

The Road Sign Assist (RSA) system on the new GS recognises traffic signs using the windscreen mounted camera, and provides information to the driver in the multi-information display. RSA can detect signs that are compliant with the Vienna Convention (including electroluminescent and flashing signs).



TEN AIRBAGS

In addition to an immensely strong passenger safety cell, occupant protection is provided by ten sensor controlled airbags. All seatbelts, except for the centre rear seat, are also specified with pre-tensioners. The driver and front passenger are protected by 2-stage head airbags, as well as knee and side airbags. Outer rear seats are equipped with side airbags as standard, while curtain shield airbags run the full length of both cabin sides. This exceptional level of safety protection is provided as standard in the new GS. As a result, injury risk is significantly reduced.



ADAPTIVE HIGH-BEAM SYSTEM

An adjustable LED Adaptive High-beam System prevents the GS from dazzling other road users. A total of 11 independent LED chips in the headlight are enabled/disabled for precise control of the illuminated and non-illuminated areas.



BLIND SPOT MONITOR

Radar devices mounted in the rear bumper detect vehicles in adjacent lanes that are not visible in the door mirrors. If the driver is indicating to change lane and a vehicle enters the blind spot, a warning signal appears in the relevant door mirror(s).

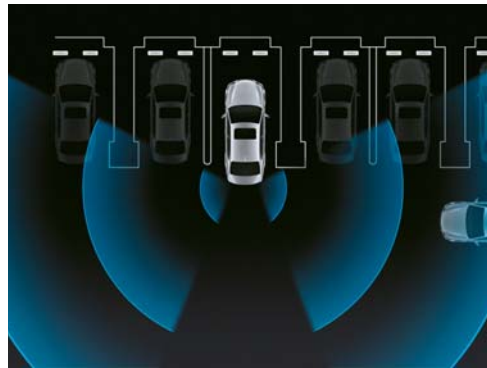

REAR CROSS TRAFFIC ALERT

The Rear Cross Traffic Alert function uses Blind Spot Monitor radar to detect vehicles approaching the area behind the vehicle in a car park. When necessary, it alerts you with a buzzer and a visual display in the door mirrors.



HEAD-UP DISPLAY

Vehicle data, such as speed, is projected directly onto the windscreen within the driver's field of vision. Navigation commands, audio settings or other selected information can also be viewed in the Head-Up Display. This lets the driver check important data without looking away from the road ahead.

EXTERIOR FEATURES



BI-LED HEADLIGHTS

The new GS is fitted as standard with compact, high-function bi-beam LED headlights. Underscored by Daytime Running Lights, a flush-type headlamp cleaner is used to ensure a smooth and aerodynamic bumper shape.



ALL-LED HEADLIGHTS

Sophisticated triple 'L'-shaped headlights use the same LED light source for both high and low beam. For a unique aura, they are accentuated by Daytime Running Lights with integrated indicators.



17" ALLOY WHEELS

Standard on Eco and Comfort grades, these lightweight 9-spoke alloys have a silver metallic finish. Specified with 225/50 R17 tyres, this combination contributes to lower CO₂ emissions and fuel consumption.



18" ALLOY WHEELS

Dynamic 5-spoke alloy wheels fitted with 235/45 R18 tyres are standard on the Luxury grade.



18" ALLOY WHEELS

These stylish 9-twin-spoke wheels with 235/45 R18 tyres are available as an option for the Luxury grade.



19" ALLOY WHEELS

Multi-spoke wheels with 235/40 R19 tyres are available as an option for the Luxury grade. With an intriguing spoke structure, these alloy wheels convey a highly dynamic impression.



RAIN SENSING WIPERS

A sensor placed above the rear-view mirror detects rainfall and its intensity. The windscreen wipers are activated, and the speed varied automatically in accordance with the amount of rain water.



HEATED DOOR MIRRORS

Aerodynamically designed, the door mirror housings incorporate an integral turn signal indicator and a discreet puddle light. The mirrors are electrically adjustable and can be heated as required.



AUTO-FOLDING

The door mirrors can be folded in electrically to help negotiate narrow spaces and, when parked, there is less risk of damage. Electro chromatic technology also dims the mirrors to prevent the risk of being dazzled by following traffic.



PARKING SENSORS

Discreetly located in the front (x4) and rear (x4) bumpers, the sensors continuously calculate the distance to the nearest object. The intensity of audio and visual warnings indicates the space remaining prior to contact.



SUNROOF

The electric, tilt and slide, glass sunroof lets the desired amount of light and air into the cabin. One-touch control is quick and convenient, while a manual sun blind provides shade as desired.



LED REAR LIGHTS AND ACTIVE BRAKE LIGHTS

Intriguingly elegant, Lexus' identity is reflected in the new 'L'-shaped rear LED lights, while integral aero-stabilising fins enhance handling stability. When braking heavily, the brake lights - including the high-level centre LED stop light - pulse rapidly to provide an effective warning to following vehicles.

INTERIOR FEATURES



HEATING / VENTILATION

In combination with leather upholstery, the driver and front passenger can individually heat or ventilate their seats as desired. This adds to the sense of bespoke luxury and is especially welcome in extreme weather conditions.



ELECTRIC SEAT ADJUSTMENT

The standard front seats feature 10-way electric adjustment, which includes 2-way lumbar support. On the F SPORT, settings increase to 16 (including 4-way lumbar support) for the driver's seat. And, in the Luxury grade, both driver and front passenger enjoy 18 individual seat adjustments, inclusive of 4 lumbar support settings.



HIGHLY SUPPORTIVE SEATS

A specialist team worked for over 5 years developing a seat structure that delivers optimum relief from fatigue. Adjustable pelvic support – a world first – together with shoulder and side support and butterfly headrests are specified on both front seats in Luxury grade models.



CALF SUPPORT

Exclusive to the Luxury grade, the driver can extend the seat cushion for improved support. And the front passenger has an extendable calf support to improve comfort and relaxation.



3-ZONE CLIMATE

Featuring world first nanoe® technology, the new GS cabin is divided into three electronically controlled climate zones. Front seat occupants input their individual settings via Remote Touch or the front panel, while rear passengers control their zone using a dedicated panel.



REAR CONTROL PANEL

The outer rear seats can also be individually heated via a convenient control panel. Located in the rear centre armrest and featuring an LCD display, it can also be used to set the rear climate zone, control the audio and operate the rear blind.



LEATHER STEERING WHEEL

A new 3-spoke leather trimmed steering wheel has been designed for the new GS. Beautifully crafted, it features buttons for audio, display, phone and voice command positioned close to the thumb tips.



LEATHER / WOOD DESIGN

On the Luxury grade, the steering wheel can optionally be specified in a leather / wood design. There is a choice of wood colour and finish: gloss or matt, and all steering wheel designs can be heated.



MULTIPLE ADJUSTMENTS

All new GS models are specified with a steering column that can be electrically adjusted for tilt and reach. In combination with multiple electric seat adjustments, all drivers will be able to obtain their ideal driving position.



PADDLE SHIFT

Although all new GS models can be driven in fully automatic mode, the steering wheel mounted paddle shift controls let the driver make swift, manual gear changes. First developed for Formula 1 cars, this technology enables a more engaging drive.



REAR SUNSHADES

An electrically operated sunshade can be specified for the rear screen. Operating smoothly and quietly, it is unobtrusive when not in use. Manual sun blinds are available for the rear door windows, complete with a sideways extension to cover the quarter light.



LUGGAGE SPACE

Boot space in the new GS 450h and GS 300h has been increased significantly. They can now accommodate three sets of golf clubs.



LED INTERIOR LIGHTING

Soft white instrument and cabin lighting gives the interior a gentle, relaxing atmosphere. Energy-efficient Light Emitting Diodes provide illumination as needed via the main dome lamp, map and reading lights, as well as permanently lighting the door panels at night.



CLASSIC TIMEPIECE

Taking pride of place in the centre of the dashboard, this classic timepiece bears testament to Lexus craftsmanship. With white LED illumination, an aura of timeless appeal is created. Using GPS, the clock will reset itself if you enter a new timezone.

AUDIO AND MULTIMEDIA



12.3-INCH MULTIMEDIA DISPLAY

The extra large 12.3-inch multimedia display allows driver and front passenger to interact using Remote Touch, while voice commands also control a number of applications. The split-widescreen is optimised for simultaneously viewing two types of information, for example large map display and DAB radio station information.



REMOTE TOUCH

Next-generation Remote Touch lets users interact intuitively with the central multimedia display. Ergonomically designed, it is close at hand and as easy to use as a computer mouse.



LEXUS PREMIUM NAVIGATION

With crisp, clear graphics and an array of mapping options, Lexus Premium Navigation is intuitive to use, reacting swiftly to user input. European road maps are conveniently stored and can be updated by Lexus Authorised Retailers.



DIGITAL CONNECTIVITY

Multiple digital applications can be synchronised to the multimedia display. For example, a smartphone's entire address book can be simply downloaded, and then scrolled through on the display. An iPhone® or other multimedia devices can be viewed and operated via different display screens.



VOICE RECOGNITION

When driving, voice commands are a convenient and safe hands-free way for the driver to control various on-board systems, such as Lexus Premium Navigation or a Bluetooth® enabled mobile phone.



STANDARD CENTRE CONSOLE

The new GS is fitted as standard with an 8-inch display screen operated by Remote Touch. This enables control of systems such as audio and climate or viewing the energy monitor, while Lexus Premium Navigation is an upgrade option. The centre console also contains the head unit for the 12-speaker audio system. It features a DAB tuner, Bluetooth® audio and CD/DVD player. Two USB ports and AUX socket are located in the console box and illuminated by white LEDs.



MULTI-INFORMATION DISPLAY

Positioned between the two main dials, the high-resolution colour multi-information display provides a wide range of vehicle information and data. The driver can select the display settings via the steering wheel mounted control.



STEERING WHEEL CONTROLS

Buttons to operate audio, phone, display and voice recognition are ergonomically integrated within the steering wheel. The optional Advanced Lane Keeping Assist switch and Adaptive Cruise Control radar button are also steering wheel mounted.



MARK LEVINSON® SOUND

Specified with a fully digital 835 W amplifier and 17 speakers utilising GreenEdge™ technology, the Mark Levinson® sound system delivers a world-class concert experience.



DIGITAL ENTERTAINMENT

Favourite DVDs can be viewed - when the vehicle is stationary - on the central display screen in all GS models. Or an iPhone® can be played through the vehicle's speakers, while viewing digital music information on the display.



PARKING ASSIST MONITOR

Engage reverse and the view behind the car is relayed to the standard 8-inch display, complete with on-screen guides to assist parking. With the 12.3-inch display, the split-screen additionally shows a parking assist sensor graphic.



COMPASS

A miniature compass is one of many secondary displays available with the navigation system. And with the 12.3-inch screen, there are a number of larger compass designs that provide exact latitude and longitude co-ordinates.

F SPORT

Developed by the team that tuned the LFA supercar, the GS 300h F SPORT and GS 450h F SPORT sedans are excitingly enhanced. For even more thrilling performance, the new GS 450h F SPORT features 'Lexus Dynamic Handling' that networks Adaptive Variable Suspension and Variable Gear Ratio Steering with Dynamic Rear Steering and Vehicle Dynamics Integrated Management.



EXCLUSIVE FRONT BUMPER AND GRILLE

With its distinctive honeycomb spindle grille and unique bumper, the eye-catching front of the F SPORT makes a bold and assertive design statement. The deeper, lower section incorporates an integral spoiler and is complemented by two separate outer mesh grilles.



F SPORT DESIGN

For exceptional handling and stability, the rear spoiler and diffuser improve down-force and aerodynamic efficiency. Exclusive F SPORT alloy wheels fitted with low-profile tyres - 235/40 (front) and 265/35 (rear) - increase cornering grip, while 356 mm, 2-piece, front disc brakes deliver immense stopping power.

LEATHER UPHOLSTERY

A new leather design, with diamond shaped perforations, has been developed exclusively for the F SPORT. Dark Rose is the signature interior colour, while all F SPORT interiors feature a black roof lining.

ALUMINIUM INLAYS

The aluminium inlays perfectly complement the machined sport pedals, scuff plates and other F SPORT interior trim elements.



F SPORT STEERING WHEEL

Grip the perforated leather steering wheel, with its F SPORT logo, and there is a tangible sense of being at-one with this high-performance sedan.



F SPORT GEARSHIFT

Finished in perforated leather, the F SPORT gearshift design matches the steering wheel to create a cohesive sense of sporting intent.



MACHINED SPORT PEDALS

Machined aluminium pedals reflect the motorport design heritage of the new GS F SPORT model. High-grip, they are exceptionally responsive.



EXCLUSIVE SCUFF PLATES

The inset front and rear door scuff plates are finished in brushed aluminium and inscribed with the LEXUS logo, exclusively in jet black.

TECHNICAL DATA

GS 300h / GS 450h

	GS 300h	GS 450h
MAXIMUM OUTPUT		
DIN hp / kW	223 / 164	345 / 254
ENGINE		
Capacity (cm ³) / Cylinders / Valves	2494 / L4 / 16	3456 / V6 / 24
Valve mechanism	Dual VVT-i	Dual VVT-i
Fuel type / Octane rating	Petrol / 95 or +	Petrol / 95 or +
Max. power (DIN hp / kW @ rpm)	181 / 133 @ 6000	292 / 215 @ 6000
Max. torque (Nm @ rpm)	221 @ 4200 - 5400	352 @ 4500
ELECTRIC MOTOR		
Type	AC synchronous, permanent magnet	AC synchronous, permanent magnet
Max. output (DIN hp / kW)	143 / 105	200 / 147
Max. torque (Nm @ rpm)	300	275
HYBRID BATTERY		
Type	Nickel-Metal Hydride (Ni-MH)	Nickel-Metal Hydride (Ni-MH)
No. of cells / System voltage (V)	192 / 650	240 / 650
TRANSMISSION		
Driven wheels	Rear-wheel drive	Rear-wheel drive
Transmission	Electronic-Continuously Variable Transmission (E-CVT)	Electronic-Continuously Variable Transmission (E-CVT)
PERFORMANCE		
Max. speed (km/h)	190	250
0 - 100 km/h (s)	9.0	5.9

	GS 300h	GS 450h
CO₂ EMISSIONS* (g/km)		
Emissions level	Euro 6	Euro 6
Combined	104 / 106 / 113 / 115 ¹	137 / 139 / 141 / 145 ¹
FUEL CONSUMPTION* (l/100 km)		
Combined	4.4 / 4.5 / 4.9 / 5.0 ¹	5.9 / 6.0 / 6.1 / 6.2 ¹
BRAKES		
Front	Ventilated discs	Ventilated discs
Rear	Ventilated discs	Ventilated discs
SUSPENSION		
Front	Double wishbone	Double wishbone
Rear	Multi-link	Multi-link
STEERING		
Type	Rack and pinion	Rack and pinion
Turns (lock to lock)	2.8	2.8
Min. turning radius (m)	5.3 / 5.1 ²	5.3 / 5.1 ²
WEIGHTS (kg)		
Gross vehicle	2235 / 2265 ³	2305 / 2335 ³
Kerb (min. - max.)	1730 - 1770 / 1735 - 1830 ³	1820 - 1860 / 1825 - 1920 ³
Towing (max. with / without brakes)	500 / -	1500 / 750
CAPACITIES (l)		
Fuel tank	66	66
Luggage compartment	450	450

¹ Figures for the GS 300h and GS 450h vary by grade and alloy wheel size. 1st figure is for the Eco grade with 17" alloy wheels. 2nd figure is for Comfort grade with 17" alloy wheels. 3rd figure is for Luxury grade with standard specification 18" alloy wheels and for Comfort grade with optional 18" alloy wheels. 4th figure is for F SPORT grade with standard specification 19" alloy wheels and Luxury grade with optional 19" alloy wheels.

² Vehicles equipped with Lexus Dynamic Handling system.

³ 1st figure(s) is (are) for the GS 300h and GS 450h Eco grade. 2nd figure(s) is (are) for all other grades, irrespective of alloy wheel size.

* The fuel consumption and CO₂ values are measured in a controlled environment, in accordance with the requirements of Directive 80/1268/EEC incl. its amendments, on a vehicle with European Standard equipment. For further information, or if you are interested in purchasing a vehicle with European Standard equipment, please contact your Lexus Authorised Importer. The fuel consumption and CO₂ values of your vehicle may vary from those measured. Driving behaviour as well as other factors (such as road conditions, traffic, vehicle condition, tyre pressure, installed equipment, load, number of passengers, etc) play a role in determining a car's fuel consumption and CO₂ emissions.

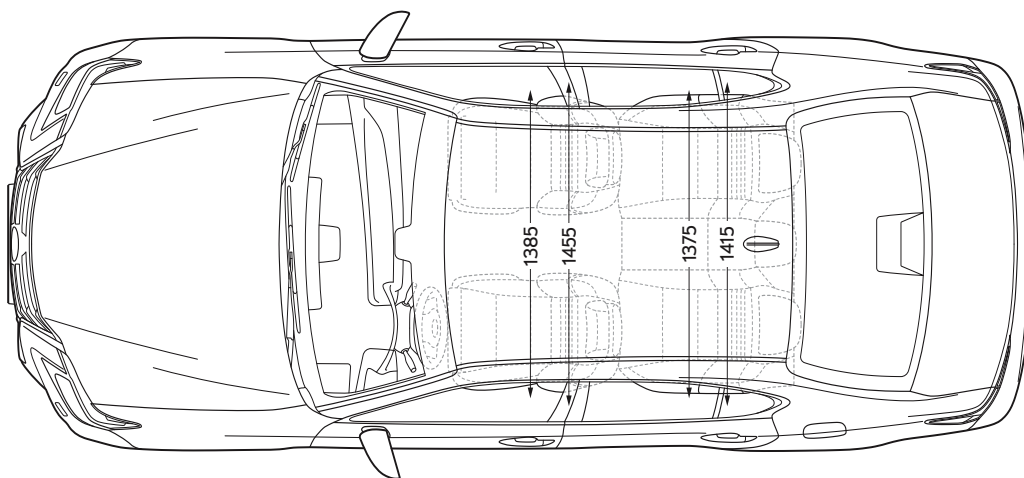
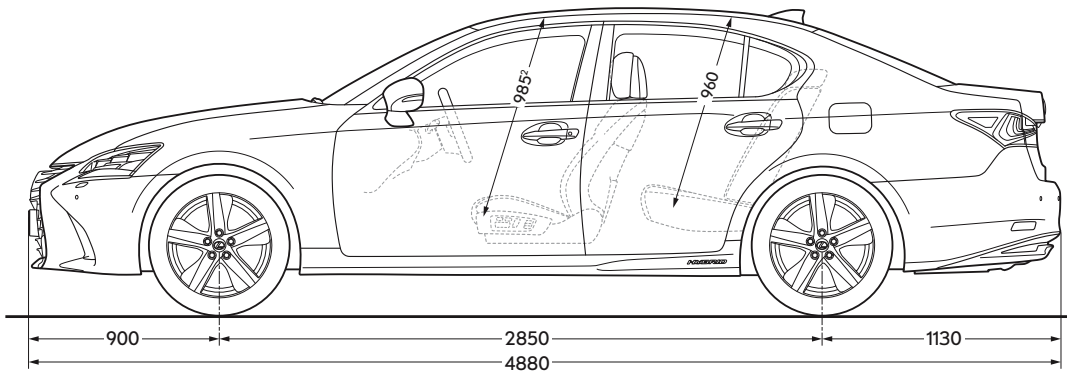
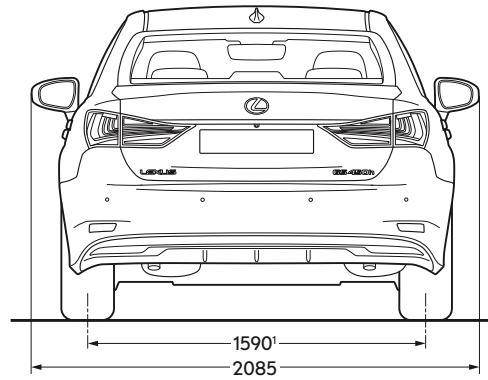
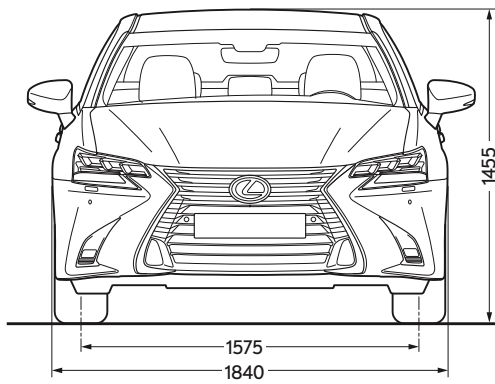

¹ Figure quoted is for the GS models specified with 17" or 18" alloy wheels. Equivalent figure with 19" alloys and 265/35 tyres specified is 1560.

² Figure quoted is for the GS models specified with the standard roof. Equivalent figure with the optional glass sunroof specified is 965.

Please note: the dimensions illustrated / noted above are measured in millimetres.

STANDARD EQUIPMENT FOR ALL GRADES

ACTIVE SAFETY AND DRIVING DYNAMICS

Active brake lights
Braking, stability, steering and traction systems¹
- ABS / BAS / EBD / EPB / EPS / TRC / VSC
EV (Electric Vehicle) mode
Hill-start Assist Control (HAC)

PASSIVE SAFETY

10 airbags in total
- driver and front passenger; head, side and knee
- outer rear seats; side
- cabin sides; full-length curtain shield
Airbag cut-off switch, front passenger
Audible and visual front seatbelts reminder
ISOFIX attachment, outer rear seats
Seatbelt pre-tensioners, front and rear outer seats

EXTERIOR

Door mirrors
- electrically adjustable, auto-folding
- auto-tilting in reverse gear
- electro chromatic (auto-dimming)
Dusk sensor with follow-me-home function
Light Emitting Diode (LED)
- daytime running lights
- front fog lights
- rear combination lights
Ultra Violet (UV) and heat insulating tinted glass

SECURITY

Anti-theft system
- immobilizer / intrusion sensor / siren
Auto door locking
Double door lock

INTERIOR COMFORT AND CONVENIENCE

Easy exit and entry facility
- driver's seat / steering wheel with retract/return function
LED ambient interior lighting
Rain sensing windscreen wipers
Rear seats, fixed
Rear-view mirror, electro chromatic (auto-dimming)
Smart entry and start system
Steering wheel
- electrically multi-adjustable
- paddle shift controls
Tyre repair kit

AUDIO, COMMUNICATION AND INFORMATION

12-speaker, DAB audio system
- in-dash, single-slot DVD player
12 V socket, front and rear
Analogue clock with GPS function and LED illumination
Bluetooth® mobile phone and audio connectivity
Lexus Media Display
- 8" multimedia screen operated by Remote Touch
- parking assist monitor with on-screen guides
Steering wheel mounted controls
- audio / display / voice / phone
Two USB ports and AUX socket

¹ ABS = Anti-lock Braking System / BAS = Brake Assist System / EBD = Electronic Brake-force Distribution / EPB = Electric Parking Brake / EPS = Electric Power Steering / TRC = Traction Control / VSC = Vehicle Stability Control

ADDITIONAL EQUIPMENT BY GRADE

ECO

(In addition to standard equipment)

- 3-spoke, leather trimmed steering wheel
- 4.2" colour TFT multi-information display
- 17" alloy wheels, 9-spoke design
 - 225/50 R17 tyres
- Cruise control
- Drive Mode Select
 - ECO / NORMAL / SPORT
- Electronic climate control
 - 2-zone
- Fabric upholstery
- Front seats, electrically adjustable
 - 2-way lumbar support (driver and passenger)
 - 10-way adjustment (driver and passenger)
- Headlights
 - bi-LED (high and low beam)
- Inlays, Black
- Leather trimmed gearshift lever
- Memory (3 pre-sets)
 - driver's seat, steering wheel and door mirrors
- Rear spoiler
- Scuff plates, aluminium

COMFORT

(In addition / different to Eco)

- Without rear spoiler

F SPORT

(In addition / different to Comfort)

- 8" colour TFT multi-information display
- 19" alloy wheels, F SPORT design,
 - 235/40 R19 (front) / 265/35 R19 (rear) tyres
- Adaptive Variable Suspension (AVS)
- Drive Mode Select
 - ECO / NORMAL / CUSTOMIZE / SPORT S/S+
- Front seats, electrically adjustable
 - 4-way lumbar support (driver)
 - 16-way adjustment (driver)
 - extending seat cushion and side support (driver)
- F SPORT exterior design elements
 - accentuated spindle grille design
 - aerodynamically enhanced front and rear bumper
 - distinctive F-mesh spindle grille
 - F SPORT logos, side and rear
- F SPORT interior design elements
 - black roof lining
 - machined aluminium sport pedals
 - front seats, F SPORT design
 - inlays, Aluminium
 - leather upholstery exclusive to F SPORT
 - perforated leather trim for steering wheel and gearshift lever
 - scuff plates, unique F SPORT design
 - steering wheel with F SPORT emblem
- Headlights
 - triple L-shaped LED
- Heated and ventilated front seats
- Lexus Safety System +
 - Adaptive Cruise Control (ACC)
 - Adaptive High-beam System (AHS)
 - Advanced Lane Keeping Assist (A-LKA)
 - Pre-Crash Safety (PCS) system
 - Road Sign Assist (RSA)
- Parking assist sensors, front and rear
- Rear spoiler
- Sunshades
 - rear window, electric / rear door windows, manual

LUXURY

(In addition / different to Comfort)

- 3-spoke, leather and wood trimmed steering wheel
- Adaptive Variable Suspension (AVS)
- Automatic boot close (soft shut)
- Drive Mode Select
 - ECO / NORMAL / CUSTOMIZE / SPORT S/S+
- Electronic climate control, 3-zone
 - with nanoe[®] technology
 - rear centre armrest with controls for climate operation
- Front seats, electrically adjustable
 - 4-way lumbar support (driver and passenger)
 - 18-way adjustment (driver and passenger)
 - butterfly front headrests
 - calf support (passenger)
 - extending seat cushion (driver)
 - shoulder and side support
- Headlights
 - triple L-shaped LED
- Heated and ventilated front seats
- Heated rear seats
- Inlays, Wood
- Lexus Safety System +
 - Adaptive Cruise Control (ACC)
 - Adaptive High-beam System (AHS)
 - Advanced Lane Keeping Assist (A-LKA)
 - Pre-Crash Safety (PCS) system
 - Road Sign Assist (RSA)
- Memory (3 pre-sets)
 - additionally for front passenger seat
- Parking assist sensors, front and rear
- Scuff plates, aluminium
- Semi-aniline leather upholstery
- Sunshades
 - rear window, electric / rear door windows, manual

OPTIONS AND PACKS

OPTIONS	ECO	COMFORT	F SPORT	LUXURY
18" alloy wheels, 5-spoke design (235/45 R18 tyres)	–	o	–	–
18" alloy wheels, 9-twin-spoke design (235/45 R18 tyres)	–	–	–	o
19" alloy wheels, multi-spoke design (235/40 R19 tyres)	–	–	–	o
Automatic boot close (soft shut)	–	o	o	s
Card key	–	–	o	o
Glass sunroof, electric tilt/slide	o	o	o	o
Head-Up Display	–	–	o	o
Heated front seats	o	o	s	s
Heated steering wheel	–	o	o	o
Parking assist sensors, front and rear	o	o	s	s

PACKS	ECO	COMFORT	F SPORT	LUXURY
Multimedia				
Lexus Premium Navigation	o	o	o	o
Lexus Premium Navigation & Mark Levinson® upgrade	o	o	o	o
Refinement & Sport				
Leather plus	o	o	s	–
Sports driving	o ¹	o ¹	s	s
Advanced Safety & Driver Assist				
Blind Spot Monitor	–	o	o	o
Lexus Safety System +	o	o	s ²	s ²

– = not available / o = available to order as an option or a pack at extra cost / s = standard

¹ GS 450h only.

² F SPORT and Luxury grades are specified with Lexus Safety System + as standard. For these grades, Automatic High Beam is replaced by the Adaptive High-beam System.

MULTIMEDIA

Lexus Premium Navigation

Lexus Premium Navigation

- 12.3" multimedia display, operated by Remote Touch
- advanced navigation system using SD card technology
- Lexus Connected Services, multiple online applications¹

Lexus Premium Navigation & Mark Levinson® upgrade

Contents of Lexus Premium Navigation
with

17-speaker Mark Levinson® Surround system

REFINEMENT & SPORT

Leather plus

Heated and ventilated front seats

Smooth leather upholstery

Sports driving

Adaptive Variable Suspension (AVS)

Drive Mode Select

- ECO / NORMAL / CUSTOMIZE / SPORT S/S+

ADVANCED SAFETY & DRIVER ASSIST

Blind Spot Monitor

Blind Spot Monitor (BSM)

- door mirrors additionally with BSM technology
- Rear Cross Traffic Alert (RCTA)

Lexus Safety System +

Adaptive Cruise Control (ACC)

Headlights, additional feature

- Automatic High Beam (AHB)

Advanced Lane Keeping Assist (A-LKA)

Pre-Crash Safety (PCS) system

Road Sign Assist (RSA)

Steering wheel mounted controls

- additionally for PCS and A-LKA

¹Please consult your local Lexus Authorised Retailer for details of the Lexus Connected Services which are available in your country.

ACCESSORIES



LEXUS HOTSPOT

Lexus Hotspot effectively turns your car into a mobile WiFi hotspot. When in a 2G/3G area, it enables connection for up to five WiFi capable devices such as tablets, phones and laptops, and supports in-car interaction between them. The system uses a SIM card of your choice and wires into the car's electrics for constant power.



WIND DEFLECTORS

Aerodynamically shaped to complement the vehicle's streamlining. When travelling with open windows, Lexus wind deflectors help maintain cabin comfort by reducing wind noise and turbulence.



ILLUMINATED SCUFF PLATES

Lexus scuff plates add a stylish design feature while also protecting the door sill paintwork. Their brushed aluminium finish is highlighted by subtle logo illumination.



REAR BUMPER PROTECTION PLATE

Style and practicality combine. The stainless steel plate guards bumper paintwork against scratching when loading or unloading the luggage space.



**Sandstone smooth leather with
Black gloss finish inlays**
(Option for Eco and Comfort)



**Black smooth leather with
Black gloss finish inlays**
(Option for Eco and Comfort)

INTERIOR COMBINATIONS

FABRIC¹

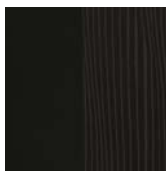

Black



Sandstone

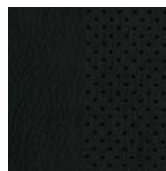

Black



Rich Cream

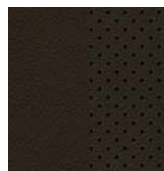

Noble Brown

SMOOTH LEATHER²

SEMI-ANILINE LEATHER³

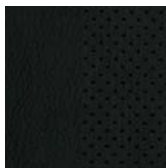

Black



Sandstone

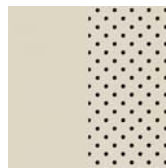

Rich Cream

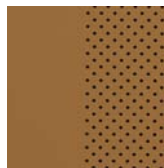

Topaz Brown

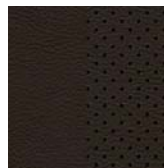

Noble Brown

F SPORT LEATHER

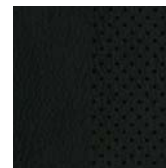

Black



Topaz Brown



Dark Rose

INLAYS⁴

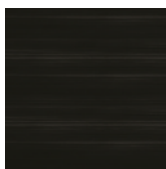

Black,
gloss finish



Black,
Shimamoku



Bamboo

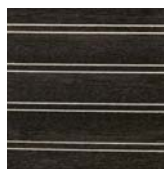

Laser Cut
Dark Wood



Open Pore
Walnut

F SPORT INLAY

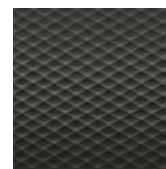

Naguri-Style
Aluminium

¹ Fabric trim is standard for Eco and Comfort grades.

² Smooth leather can be ordered as part of the leather plus pack option for Eco and Comfort grades.

³ Semi-aniline leather is standard for Luxury grade.

⁴ Black gloss finish inlay is standard for Eco and Comfort grades, while Black Shimamoku or Bamboo inlays are standard for the Luxury grade. Black Shimamoku, Bamboo or Open Pore Walnut inlays are available as an option for Comfort grade, in combination with the leather plus pack. Open Pore Walnut or Laser Cut Dark Wood inlays are available as an option for Luxury grade.

The images on the following 3 pages illustrate a selection of the interior combinations available. Your local Lexus Authorised Retailer will be pleased to provide you with any further help.

Noble Brown smooth leather with Black gloss finish inlays

(Option for Eco and Comfort)



Dark Rose F SPORT leather with Naguri-Style Aluminium inlays

(F SPORT)



INTERIOR COMBINATIONS

Rich Cream semi-aniline leather with Black Shimamoku inlays
(Luxury)



Topaz Brown semi-aniline leather with Bamboo inlays
(Luxury)



Sandstone semi-aniline leather with optional Laser Cut Dark Wood inlays

(Luxury)



Black semi-aniline leather with optional Open Pore Walnut inlays

(Luxury)



EXTERIOR COLOURS

F WHITE (083)¹



SONIC WHITE (085)²



SONIC SILVER (1J2)



SONIC TITANIUM (1J7)



MERCURY GREY (1H9)



BLACK (212)³



GRAPHITE BLACK (223)



MORELLO RED (3R1)



SAPPHIRE BLUE (8X1)¹



DEEP BLUE (8X5)²



COPPER BROWN (4X2)²



¹ Exclusive to F SPORT.

² Not available for F SPORT.

³ Solid colour

Please note: due to printing variances, actual paintwork colours may vary slightly from those illustrated.

THE NEW GS

LEXUS CARE



**AT LEXUS,
WE CARE**

OMOTENASHI
BY LEXUS

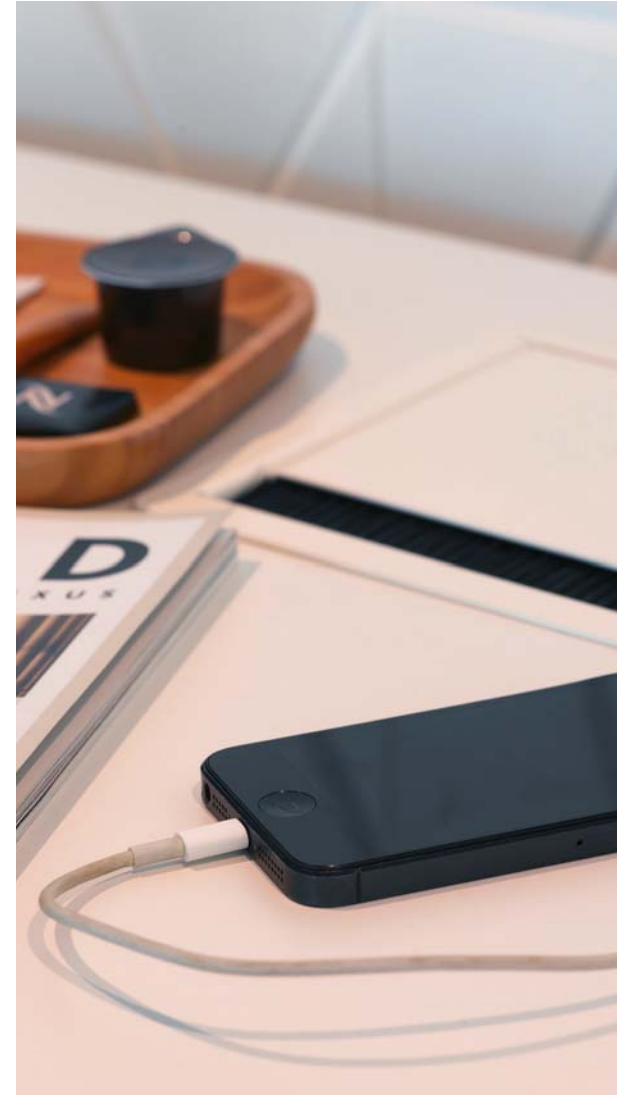

**AT LEXUS WE SEE YOU
MORE AS A GUEST
THAN A CUSTOMER.**



Reflecting our passionate commitment to 'Omotenashi' - the Japanese spirit of hospitality that inspires our world-class customer service - at Lexus we aim to treat every customer as if they were a guest in our own home. Throughout your vehicle's life, we'll strive to ensure an amazing ownership experience, offering peerless service and seamless maintenance work, all orchestrated to provide complete satisfaction and total peace of mind.

Ever since the launch of the Lexus LS 400 flagship sedan in 1989, Lexus has always believed in going 'the extra mile' for every single customer. Evidenced by countless awards over the last 25 years, we see caring for your car as the equivalent of caring for you.

When you visit our showrooms, we endeavour to anticipate your every need and make available the finest facilities for you to enjoy a warm and relaxed atmosphere. In the modern Lexus lounge, you can catch up on news, browse the Internet, or enjoy refreshments. While you relax, Lexus technicians will work with precision and efficiency to get you back on the road with minimum interruption to your day.



EXPERIENCE THE NEW GS 300h / GS 450h

Please contact your nearest Lexus Authorised Retailer for a test drive.

More about the new GS:

www.lexus.eu/gs

www.facebook.com/LexusEurope

www.youtube.com/LexusEurope

www.twitter.com/LexusEurope

© 2015 Lexus Europe* reserves the right to alter any details of specifications and equipment without notice. Details of specifications and equipment are also subject to change to suit local conditions and requirements. Please enquire at your local Lexus Authorised Retailer of any such changes that might be required for your area.

Note: vehicles pictured and specifications detailed in this brochure may vary from models and equipment available in your area. Vehicle body colour might differ slightly from the printed photos in this brochure.

For further information please visit our website: www.lexus.eu

Taking care of the environment is a priority for Lexus. We take many measures to ensure that during the lifecycles of our vehicles - from design, production, distribution, sales and service to end-of-life - their environmental impact is minimised. Your retailer will be happy to provide more information on end-of-life vehicle requirements.

* Lexus Europe is a division of Toyota Motor Europe NV/SA.

Printed in Europe, November 2015

