

THE NEW RC F





THE NEW RC F

Introduction	04 - 07
V8 Performance	08 - 09
Driving Dynamics	10 - 11
Design	12 - 13
Carbon Pack	14 - 15
Interior Luxury	16 - 21
Advanced Technology	22 - 23
Innovative Safety	24 - 25
Lexus Quality	26 - 27
Technology & Specifications	28 - 51





"WE CREATED THE NEW RC F SPORTS COUPÉ TO DELIVER
MAXIMUM ENJOYMENT, WHETHER ON THE RACETRACK
OR OPEN ROAD."

Yukihiko Yaguchi, RC F Chief Engineer

AMAZING IN MOTION

With its exquisitely crafted steering wheel in your hands, the all-new RC F sports coupé delivers breathtaking acceleration, and exhilarating high-speed performance right up to 270 km/h on the racetrack. This latest 'F model' was developed at the Lexus technical centre near Fuji Speedway (its toughest curves appear in the 'F' marque logo) by the same engineering team that created our legendary LFA supercar and IS F high-performance sedan. Featuring an extraordinarily rigid chassis, combined with motorsport-inspired aerodynamics and race-tuned V8 engine, the new RC F takes you to a new level of driving excitement.



THE NEW RC F

THRILLING TO DRIVE, THIS ALL-NEW LEXUS SPORTS COUPÉ FUSES MUSCULAR LOOKS WITH LEADING EDGE MOTORSPORT TECHNOLOGY.

Engineered for sheer exhilaration, the new RC F is one of the most amazing high-performance 2+2 sports coupés ever created. Aggressive styling displays race-bred aerodynamics and impressive 19-inch forged alloy wheels, while the interior features LFA-inspired instruments. Under the bonnet, the most powerful V8 engine ever developed by Lexus delivers its awesome power to the rear wheels via a rapid 8-speed Sport Direct Shift automatic transmission. When downshifting, you'll experience the addictive sound of the throttle 'blipping' between gears, while a Torque Vectoring Differential ensures high-speed control.



THE NEW RC F V8 PERFORMANCE

ENGINEERED FOR EXHILARATION

RELISH THE MOST POWERFUL LEXUS V8 ENGINE EVER BUILT, ENDURANCE TESTED AT THE WORLD'S TOUGHEST RACETRACKS.

Driven at the gruelling Nürburgring 24-hour race and Pikes Peak Hill Climb in Colorado, this new hand-built 5.0-litre V8 engine resets benchmarks for sports performance. Developing 477 DIN hp and 530 Nm of torque, it creates an amazing soundtrack, delivering a low tone up to 3000 rpm and a higher-pitched roar above 6000 rpm. The cylinder head and other moving parts are engineered by Yamaha Motorsport (who supplied the LFA's V10 engines), while assembly and tuning take place at our Tahara plant.

BREATHTAKING CURVES

DRIVING THE ALL-NEW RC F, YOU'LL SAVOUR EVERY HIGH-SPEED STRAIGHT, BANKED CURVE OR HAIRPIN BEND.

Developed and tuned by Lexus 'Master Drivers', the new RC F offers an unforgettable drive. Supreme cornering agility comes from the car's short wheelbase and extremely rigid chassis, built using the latest adhesive and laser screw-welding technology. Multi-link rear and double wishbone front suspension combine with motorsport aerodynamics to deliver a world-class driving experience. Drive Mode Select and a Torque Vectoring Differential let you tune the RC F to suit your mood, while our latest Sports VDIM ensures high-speed driving refinement and safety.





PASSION FOR PERFORMANCE

EXTRA-WIDE 'SPINDLE GRILLE' AND AIR INTAKES, ACTIVE REAR WING FOR MORE DOWNFORCE, ADVANCED UNDERBODY AERODYNAMICS.

Muscular and aggressive, our new high-performance sports coupé features an extra-wide Lexus 'spindle grille' with 'F' motif mesh. Jewel-like, triple 'L' LED headlights are underscored by L-shaped LED daytime running lights for an unmistakable Lexus look. The RC F's striking side profile is further enhanced by a choice of four 19" forged alloy wheels. As on the LFA supercar, an active rear spoiler creates extra downforce at speeds above 80 km/h, while quadruple exhaust outlets complete the powerful stance.

MATERIAL ADVANTAGE

THE RC F 'CARBON PACK' FEATURES LIGHTWEIGHT COMPONENTS MADE USING PIONEERING LEXUS COMPOSITE TECHNOLOGY.

Benefiting from carbon fibre moulding technology developed for our LFA supercar and IS F CCS-R racecar, the RC F 'carbon pack' model is 9.5 kilos lighter than the standard car. Carbon fibre elements include the roof, bonnet and active rear wing. Woven carbon fibre components create an attractive visual form, while an exclusive clear lacquer ensures excellent weather resistance. As well as reducing overall weight, the carbon package also lowers the RC F's centre-of-gravity by 3 mm. This contributes to the enhanced dynamic performance achieved through a reduced roll inertia moment.





POLE POSITION

DRIVER-FOCUSED COCKPIT, HIGH-BACK LEATHER SPORTS SEATS, LFA-STYLE CENTRAL INSTRUMENTS WITH G-FORCE METER.

Relax and feel confident around fast corners in the RC F's beautifully crafted high-back sports seats. Inspired by the latest innovative sportswear, they are manufactured using an integrated foaming technique for a very supportive fit. The RC F's instruments represent a further development of the LFA's unique central dial - information shown includes a large tachometer, digital and analogue speed readouts, a Torque Vectoring Differential monitor, a G-Force meter and even a stopwatch. Soft-touch materials, a precision analogue timepiece and LED ambient lighting complete the impressive interior.



DRIVER HOSPITALITY

ENJOY A JAPANESE 'OMOTENASHI' WELCOME, WHILE LISTENING TO THE WORLD-CLASS 17-SPEAKER MARK LEVINSON® PREMIUM AUDIO.

Approach the RC F with the key in your pocket and both door handles will illuminate to greet you, unlocking when touched. Beautifully engineered, they have no keyhole to disrupt their pure design. Once inside you'll appreciate the powerful yet efficient air conditioning that can be adjusted using electrostatic controls on the centre console. The RC F is also the perfect place to enjoy the 17-speaker Mark Levinson® Premium Audio system. It delivers a peerless 7.1-channel digital home-theatre experience, enhanced by Clari-Fi™ that rebuilds sound lost in MP3 digital compression.





ONBOARD COMMUNICATION

7-INCH MULTIMEDIA DISPLAY, INTUITIVE TOUCH PAD ACCESS TO LEXUS PREMIUM NAVIGATION AND CONNECTED SERVICES.

Wherever you drive in Europe, you'll navigate easily in the RC F. Its innovative new Touch Pad lets front seat occupants interact intuitively with the central 7-inch multimedia display. This also functions as a Parking Assist Monitor for trouble-free reversing. Lexus Premium Navigation features vivid 3D graphics and can even generate a QR code for your smartphone, to help you reach your final destination on foot. The RC F is equipped with the latest Lexus Connected Services like Online Search, Google Street View®, Panoramio® and Connected Traffic.

SUPERIOR PROTECTION

SPORTS VDIM, BLIND SPOT MONITOR AND REAR CROSS TRAFFIC ALERT SUPPORT YOUR DRIVING SKILLS.

Equipped with Sports Vehicle Dynamics Integrated Management (VDIM) and huge ventilated disc brakes, the new RC F is engineered to help you avoid danger. Adaptive Cruise Control lets you maintain a safe distance between you and the car ahead (even if that vehicle slows down) while Blind Spot Monitor and Rear Cross Traffic Alert detect vehicles you may not have seen. Should a collision seem likely, a sophisticated Pre-Crash Safety system takes over. If an impact is unavoidable, you are protected by a strong passenger safety cell and eight airbags.





IMPECCABLE FINISH

**WHITE GLOVED LEXUS MASTER CRAFTSMEN
OVERSEE PRODUCTION AND INSPECT EVERY
RC F IN A 'QUIET ROOM' BEFORE DELIVERY.**

The new RC F is built at our award-winning Tahara plant by Lexus 'Takumi' craftsmen. With at least 25 years of experience, each is an expert at detecting the tiniest imperfections. You'll sense their amazing skill when you first touch the precision-machined aluminium audio controls or beautifully stitched leatherwork. Gleaming paintwork is painstakingly wet sanded by hand to ensure a perfect finish. Before a final test drive, the 'Takumi' check each car for smooth running in a 'quiet room' using their highly trained ears and a sensitive microphone placed strategically in the cabin.



TECHNOLOGY & SPECIFICATIONS

Racetrack Performance	30 - 31
Advanced Safety	32 - 33
Exterior Features / Interior Features	34 - 35
Audio and Multimedia	36 - 37
Technical Data	38 - 39
Standard / Additional Equipment	40 - 41
Options and Packs	42 - 43
Accessories	44 - 45
Interior Combinations	46 - 47
Exterior Colours	48 - 49
Lexus Care	50 - 51



RACETRACK PERFORMANCE

Developed on the world's toughest circuits, Chief Engineer Yukihiro Yaguchi and his team have created the RC F to be enjoyed by all motorsport enthusiasts, no matter what their level of expertise. Whether on the racetrack or open road, the car's driving dynamics can be modified instantly to meet your driving style.



FRONT SUSPENSION

Featuring forged aluminium components, the double wishbone front suspension is lightweight and responsive. Innovative suspension geometry delivers excellent handling stability and ride comfort.

REAR SUSPENSION

Straight-line and cornering stability are supplied by a multi-link rear suspension setup first used on the much-acclaimed GS performance sedan. A combination of high-tensile steel and die-cast/forged aluminium components keep weight low but ensure vibration-free precision.

TORQUE VECTORING DIFFERENTIAL

Designed to further heighten driving enjoyment, the RC F features a Torque Vectoring Differential with three operating modes: STANDARD, for a balance of agile performance and high-speed stability, SLALOM, for an emphasis on nimble response to steering inputs and TRACK, for consistent, stable cornering behaviour while circuit driving.

RIGID CHASSIS

The foundation for the new RC F's outstanding handling is its high rigidity body. Numerous specialised manufacturing techniques further enhance strength, including body adhesives, laser-screw welding and multi-spot welding. The RC F is equipped with coil-sprung independent suspension systems front and rear, incorporating mono-tube gas dampers and stabiliser bars.



V8 ENGINE

Hand built and stethoscope tuned, this incredible 5.0-litre V8 engine develops 477 DIN hp and 530 Nm of torque. The cylinder head and all moving parts are designed to provide increased maximum power at higher revs. Thrilling to hear, advanced sound engineering creates a deeply resonant tone up to 3000 rpm, and a higher-pitched roar as revolutions rise above 6000 rpm under hard acceleration.



FORGED ALLOY WHEELS

The RC F's wheels are forged (rather than cast) in a process that emulates the blows of a blacksmith's hammer to combine strength through an improved metallic structure, with lightness.



8-SPEED TRANSMISSION

The V8 engine delivers power via an 8-speed Sport Direct Shift sequential transmission with manual override. Select Manual mode and use shift paddles to enjoy rapid sports performance. When paddle downshifting (in just 0.2 seconds) you'll experience the unique sound of the throttle 'blipping' between gears.



ADVANCED AERODYNAMICS

The new RC F has superb aerodynamics, thanks to details like a near-flat underbody and tiny winglets on the front door pillars. First seen on F1 racing cars, these winglets create air vortices that help pull the airstreams inwards to improve the way the car cuts through the air.



DRIVE MODE SELECT

Vehicle performance can be fine-tuned using Drive Mode Select. ECO mode reduces emissions and conserves fuel while, for everyday driving, NORMAL provides an ideal balance of power, economy and ride comfort. For enhanced drivetrain responsiveness, simply switch to SPORT S or SPORT S+ mode.

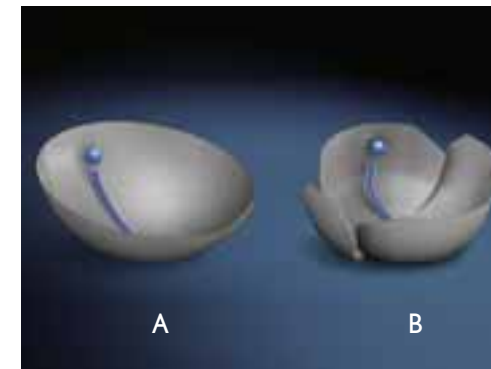

SPORTS VDIM

Sports Vehicle Dynamics Integrated Management (VDIM) ensures that the enormous power of the RC F can be enjoyed smoothly and safely. This adjusts throttle, steering and suspension settings to provide sportier performance, and expands the permissible range of centrifugal force before the VDIM system intervenes. If you're ready to push the RC F to the extreme, you can switch Sports VDIM off completely.

A. With VDIM. Dynamic control systems work smoothly together.
B. Without VDIM. Dynamic control systems work independently.

ADVANCED SAFETY

As well as having the latest Sports Vehicle Dynamics Integrated Management, the new RC F is equipped with huge brakes to help you avoid danger. Pioneering driver support systems include Pre-Crash Safety, Adaptive Cruise Control, Lane Departure Alert and Automatic High Beam. An incredibly strong passenger safety cell and eight airbags provide exceptional occupant protection.



■ PRE-CRASH SAFETY / LANE DEPARTURE ALERT / AUTOMATIC HIGH BEAM

Millimetre-wave radar and an on-board computer calculate collision risk ahead. If the risk is high, the driver is alerted by audible and visual warnings and brake pressure is increased. When a collision is deemed unavoidable, the brakes will be applied automatically as necessary and the front seatbelts tightened. Adaptive Cruise Control uses the same radar technology to maintain a set distance to the vehicle ahead. A camera mounted behind the rear-view mirror enables Lane Departure Alert to warn you if you inadvertently drift out of lane. Automatic High Beam uses the same camera at night to automatically switch to low beam when it detects the lights of either an oncoming or preceding vehicle.

■ Available as an option, part of a pack or standard on specific grade(s).

■ BLIND SPOT MONITOR

Radar devices mounted in the rear bumper detect vehicles in adjacent lanes that are not visible in the door mirrors. If the driver is indicating to change lane and a vehicle enters the blind spot, Blind Spot Monitor instantly activates a warning signal in the relevant door mirror.



■ EIGHT AIRBAGS

RC F occupant safety is provided by eight airbags. The driver and front passenger are protected by 2-stage head airbags, as well as knee and side airbags. Curtain shield airbags run the full length of both cabin sides. All seatbelts are also specified with pre-tensioners.



■ REAR CROSS TRAFFIC ALERT

When reversing, for instance in a busy car park, Rear Cross Traffic Alert (RCTA) uses Blind Spot Monitor radar to identify vehicles approaching the difficult-to-see area behind the vehicle. When a vehicle is detected, the RCTA function alerts you with a visual display in the door mirrors and a buzzer.

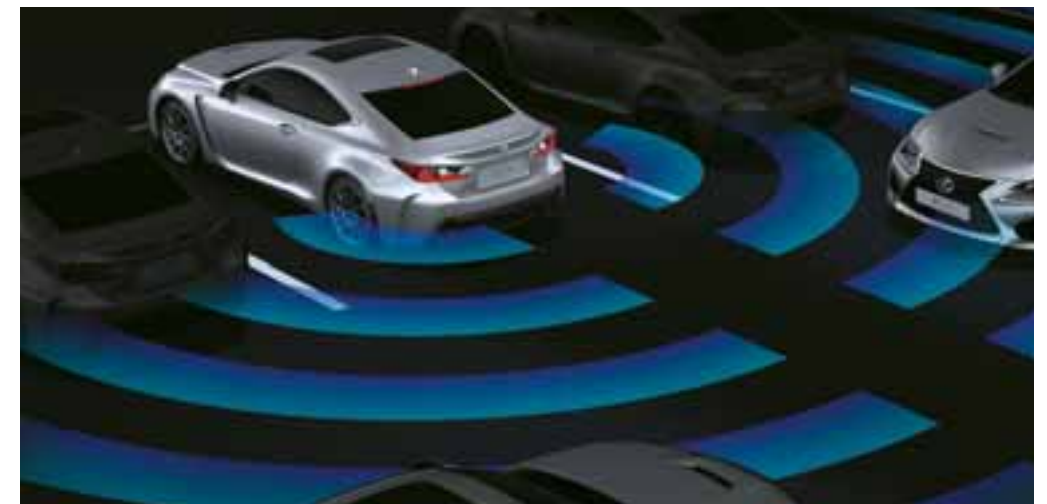

EXTERIOR FEATURES



TRIPLE LED 'L' BEAMS / LED DRL

Jewel-like, triple 'L' LED headlights use the same light source for high and low beam, with the RC F's impressive aura enhanced by L-shaped thick-wall full LED daytime running lights.



LED REAR LIGHTS

The rear light cluster combines elegant LEDs arranged in Lexus signature 'L' form. Thick-wall moulding technology gives a crystal appearance, and a strikingly bold presence even when not illuminated.



19" FORGED ALLOYS

This muscular 10-spoke wheel is both lightweight and rigid, fitted with 255/35 R19 (front) and 275/35 R19 (rear) low profile tyres.



19" FORGED ALLOYS

Three-dimensionally machined spokes give a sharp look and reflect the excellent dynamic performance of our latest 'F' model.



19" FORGED ALLOYS

This hand-polished wheel features Lexus 'L'-motif spokes that combine Takumi craftsmanship with advanced weight reduction technology.



19" FORGED ALLOYS

Featuring distinctive Lexus 'L'-motif spokes with a dark metallic finish, this wheel is forged for extreme structural strength and lightness.

INTERIOR FEATURES

DRIVER-FOCUSED COCKPIT

The new RC F's driver-focused cockpit will keep you perfectly relaxed and concentrated on the road or track ahead. Behind the beautifully crafted steering wheel the sumptuous front seats offer up to 8-way electric adjustments.

SPORTS STEERING WHEEL

The RC F debuts a Lexus-first elliptical cross-section, thick grip steering wheel that offers greater control during performance driving. The placement, shape and operation of the wheel's paddle shifts have also been optimised for fast, accurate gear changes.



LEATHER SPORTS SEATS

All-new high-back seats feature Lexus' integrated foaming, which gives a cossetting, highly supportive fit. This motorsport-inspired technology allows greater comfort and lateral support than is possible with conventional upholstery.

HEATED / VENTILATED SEATS

The driver and front passenger can heat or ventilate their leather seats. This adds to the sense of luxury, especially in extreme weather conditions.



AUDIO AND MULTIMEDIA



LEXUS NAVIGATION

Intuitive full map pan-European navigation is integrated within the Lexus Media Display. Features include a choice of 20 languages, 3D map graphics, lane guidance and RDS-TMC traffic information.



CENTRAL DIGITAL INSTRUMENTS

The RC F's all-new instrument meters represent a further development of the LFA's switchable, driving mode-dependent central dial. Information includes a large, centrally-mounted tachometer that alters according to driving mode. There are also digital and analogue speed readouts, a Torque Vectoring Differential monitor, a G-Force meter, oil and water temperature gauges, mileage information and even a stopwatch.



PARKING ASSIST MONITOR

Engage reverse and the view behind the car is relayed to the Lexus Media Display. On-screen guides are also displayed to assist parking.



MARK LEVINSON®

The RC F's 17-speaker, 835 Watt Mark Levinson® Premium Surround system is tailored to the acoustic properties of the cabin. It delivers a peerless 71-channel digital home-theatre experience, enhanced by Clari-Fi™ that rebuilds sound lost in MP3 digital compression.



DIGITAL CONNECTIVITY

Multiple digital applications can be synchronised to the Lexus Media Display. For example, simply download your smartphone's entire address book and then scroll through it. Different screens let you view and operate an iPhone or other multimedia devices.



LEXUS HOTSPOT

Special automotive design enabling connectivity for up to 5 WiFi devices such as mobile phones and tablets. It wires into the car electrics, has a high-speed antenna and uses your choice of SIM card.



LEADING EDGE MULTIMEDIA

The new RC F has the very latest Lexus multimedia technology. This features Lexus Premium Navigation and Lexus Connected Services like Google Street View®. It can even help you calculate the most ecological route.



TOUCH PAD

Touch Pad with Remote Touch Interface lets front seat occupants interact intuitively with the central 7-inch multimedia display. Ergonomically designed, it is as easy to use as a smartphone or tablet.



LEXUS PREMIUM NAVIGATION

With vivid 3D graphics and many mapping options, the 7-inch screen is operated by Touch Pad or voice commands. The system can even generate a QR code for your smartphone, to help you reach your final destination on foot.



LEXUS CONNECTED SERVICES

The new RC F offers services like Online Search, Google Street View®, Panoramio® or Connected Traffic. For extra convenience you can even forward a route from your laptop or tablet to the RC F's navigation system.

■ Available as an option, part of a pack or standard on specific grade(s).
○ Available as an accessory.

TECHNICAL DATA

	RC F
TOP-LINE DATA	
Maximum Output (DIN hp / kW)	477 / 351
CO ₂ emissions* (g/km)	251
0-100 km/h (seconds)	4.5
Top speed (km/h)	270 ¹
Drag coefficient (Cd)	0.33
ENGINE	
Capacity (cm ³)	4969
Cylinders / Valves	V8 / 32
Max. power (DIN hp / kW @ rpm)	477 / 351 @ 7100
Max. torque (Nm @ rpm)	530 @ 4800 - 5600
TRANSMISSION	
Driven wheels	Rear-wheel drive
Transmission	8-speed Sport Direct Shift automatic transmission
FUEL CONSUMPTION*	
Urban (l/100 km)	16.1
Extra urban (l/100 km)	7.8
Combined (l/100 km)	10.8
Fuel tank capacity (l)	66
LUGGAGE CAPACITY (l)	
All seats upright	366 ¹

Please note: the information presented is based on manufacturer's preliminary data and is subject to change without notice.

¹Based on manufacturer's own data.

* The fuel consumption and CO₂ values are measured in a controlled environment, in accordance with the requirements of Directive 80/1268/EEC incl. its amendments, on a vehicle with European Standard equipment. For further information, or if you are interested in purchasing a vehicle with European Standard equipment, please contact your Lexus Authorised Importer.

The fuel consumption and CO₂ values of your vehicle may vary from those measured. Driving behaviour as well as other factors (such as road conditions, traffic, vehicle condition, tyre pressure, installed equipment, load, number of passengers, etc) play a role in determining a car's fuel consumption and CO₂ emissions.

Please note: further Technical Data, including any updates, can be found at www.lexus.eu

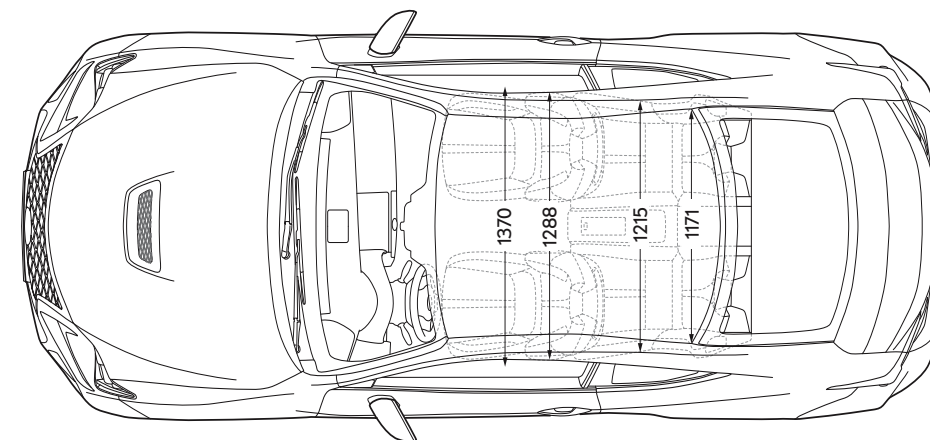
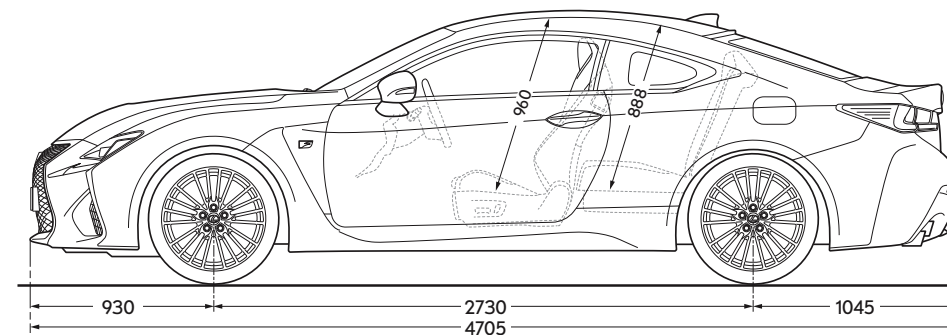
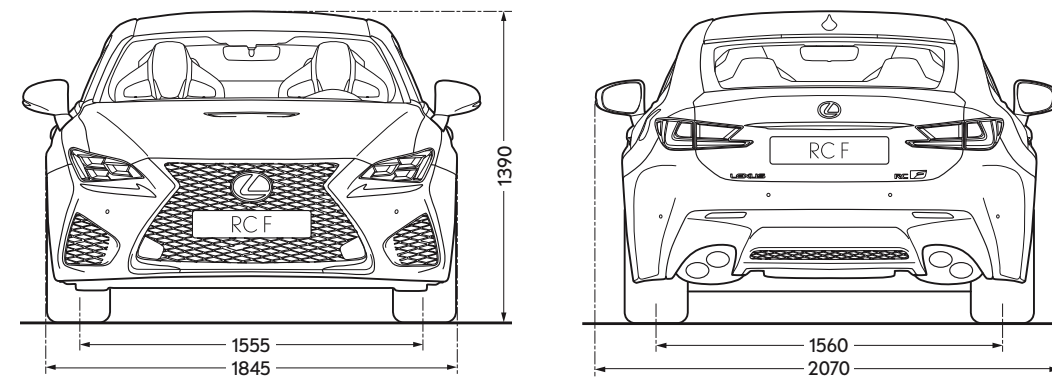

Please note: the dimensions illustrated above are measured in millimetres.

STANDARD EQUIPMENT FOR ALL GRADES

ACTIVE SAFETY AND DRIVING DYNAMICS

Active brake lights
Auto Location Tyre Pressure Warning System (AL-TPWS)
Braking, stability, steering and traction systems¹
- ABS / BAS / EBD / ECB / EPS / TRC / VSC
Drive Mode Select
- ECO / NORMAL / SPORT S / SPORT S+
Hill-start Assist Control (HAC)
Vehicle Dynamics Integrated Management (VDIM) with Sport Mode

PASSIVE SAFETY

8 airbags in total
- cabin sides; full-length curtain shield
- driver and front passenger; head, side and knee
Airbag cut-off switch, front passenger
Audible and visual front seatbelts reminder
ISOFIX attachment, outer rear seats
Seatbelt pre-tensioners, front and rear outer seats

EXTERIOR

Door mirrors
- electrically adjustable and heated
- electrically auto-folding
- electro chromatic (auto-dimming)
- integral turn signal indicators and puddle lights
F logos, side and rear
Laser-brazed roof structure
Light Emitting Diode (LED)
- daytime running lights
- L-shaped headlights with auto-levelling cleaners
- rear combination lights
Parking assist sensors, front and rear
Rear spoiler
- electrically retractable
Ultra Violet (UV) and heat insulating tinted glass
Water-repellent glass, front door windows

SECURITY

Anti-theft system
- immobiliser / intrusion sensor / siren
Auto door locking
Double door lock

AUDIO, COMMUNICATION AND INFORMATION

4.2" colour multi-information display
- F logo animation
- G-sensor
- lap timer function
- torque distribution display
Active Sound Control
Analogue clock with white LED illumination
Bluetooth® mobile phone and audio connectivity
Lexus Media Display
- 7" display screen operated by rotary dial
- AM/FM tuner
- antenna for tuner incorporated within rear screen
- GPS ready
- parking assist monitor
Optitron instrumentation
Steering wheel mounted controls
- audio / display / phone / voice
Two USB ports and AUX socket

INTERIOR COMFORT AND CONVENIENCE

12 V socket
Cruise control
Drilled sports pedals and footrest
Electrically operated windows
Electronic climate control
- 2-zone
Front centre armrest and storage box
Front and rear seat headrests, F-logo embossed
Front sports seats (driver and passenger)
- 8-way electrically adjustable
Illuminated entry system
Leather trimmed gearshift lever
Memory function for front seat (driver only), door mirrors and steering wheel
Push start button
Rain sensing windscreen wipers
Rear-view mirror, electro chromatic (auto-dimming)
Rear centre console, fixed²
- armrest and through-load facility
Sports perforated leather steering wheel, F-logo embossed
- electrically multi-adjustable
- paddle shift controls
Tyre repair kit

ADDITIONAL EQUIPMENT BY GRADE

EXECUTIVE

(In addition to standard equipment)

6-speaker audio system with Gracenote®
19" forged aluminium wheels, 10-spoke design
- 255/35 R19 (front) and 275/35 R19 (rear) tyres
Alcantara trim, seat upholstery
Heated front seats
In-dash, single-slot CD player

LUXURY

(In addition / different to Executive)

10-speaker, DAB audio system
19" forged aluminium wheels, 10-twin-spoke design
- 255/35 R19 (front) and 275/35 R19 (rear) tyres
Automatic High Beam (AHB)
Blind Spot Monitor (BSM)
- door mirrors additionally with BSM technology
Electro multi-vision display
In-dash, single-slot CD/DVD player
Lane Departure Alert (LDA)
Lexus Premium Navigation with Connected Services¹
- Digital Terrain Model / Route Trace Registration
- Ecological Route / Speed Camera Guidance
- Online Search / Google Street View® / Panoramio®
- Send Route to Car / Connected Traffic / Traffic Bar
- Urgent Traffic Event Notification / QR code of destination
Parking assist monitor with on-screen guides
Rear Cross Traffic Alert (RCTA)
Touch Pad operation
Semi-aniline perforated leather seat upholstery
- heated and ventilated front seats (driver and passenger)

CARBON

(In addition / different to Executive)

10-speaker, DAB audio system
19" forged aluminium wheels, L-shaped motif design
- 255/35 R19 (front) and 275/35 R19 (rear) tyres
Electro multi-vision display
Glove box, carbon trim
In-dash, single-slot CD/DVD player
Lexus Premium Navigation with Connected Services¹
- Digital Terrain Model / Route Trace Registration
- Ecological Route / Speed Camera Guidance
- Online Search / Google Street View® / Panoramio®
- Send Route to Car / Connected Traffic / Traffic Bar
- Urgent Traffic Event Notification / QR code of destination
Parking assist monitor with on-screen guides
Roof, bonnet, rear spoiler
- carbon finish
Touch Pad operation

¹ ABS = Anti-lock Braking System / BAS = Brake Assist System / EBD = Electronic Brake-force Distribution / ECB = Electronically Controlled Braking / EPS = Electric Power Steering / TRC = Traction Control / VSC = Vehicle Stability Control

² Four seat capacity

¹Please consult your local Lexus Authorised Retailer for details of the Lexus Connected Services which are available in your country.

OPTIONS AND PACKS

OPTIONS	EXECUTIVE	LUXURY	CARBON
19" forged aluminium wheels, 10-twin-spoke design - 255/35 R19 (front) and 275/35 R19 (rear) tyres	o	s	-
19" forged aluminium wheels, L-shaped motif design, Polished - 255/35 R19 (front) and 275/35 R19 (rear) tyres	o	o	s
19" forged aluminium wheels, L-shaped motif design, Dark finish - 255/35 R19 (front) and 275/35 R19 (rear) tyres	o	o	-
Torque Vectoring Differential (TVD)	o	o	o
Heated steering wheel	o	o	o
Glass sunroof, electric tilt/slide	o	o	-

PACKS	EXECUTIVE	LUXURY	CARBON
Multimedia			
Navigation plus & Audio upgrade (Pack 1)	o	s	s
Navigation plus & Mark Levinson® upgrade (Pack 2)	o	o	o
Comfort			
Leather plus	o	s	o
Advanced Safety & Driver Assist			
Pre-Crash Safety (PCS)	o	o	o
Lane Departure Alert (LDA)	o	s	o
LDA with Automatic High Beam (AHB)	-	s	o
LDA with AHB and Blind Spot Monitor (BSM)	-	-	o

- = not available / o = available to order as an option or a pack at extra cost / s = standard

MULTIMEDIA

Navigation plus & Audio upgrade (Pack 1)

10-speaker, DAB audio system
Electro multi-vision display
In-dash, single-slot CD/DVD player
Lexus Premium Navigation with Connected Services¹
- Digital Terrain Model / Route Trace Registration
- Ecological Route / Speed Camera Guidance
- Online Search / Google Street View® / Panoramio®
- Send Route to Car / Connected Traffic / Traffic Bar
- Urgent Traffic Event Notification / QR code of destination
Parking assist monitor with on-screen guides
Touch Pad operation

Navigation plus & Mark Levinson® upgrade (Pack 2)

Audio upgraded from 10-speaker version to:
17-speaker Mark Levinson® entertainment system
Contents of Pack 1 (see above)

COMFORT

Leather plus

Heated and ventilated front seats (driver and passenger)
Leather seat upholstery (perforated)

ADVANCED SAFETY & DRIVER ASSIST

Pre-Crash Safety (PCS)

Adaptive Cruise Control (ACC)²
PCS system with millimetre-wave radar

Lane Departure Alert (LDA)

Blind Spot Monitor (BSM)
- door mirrors additionally with BSM technology
Lane Departure Alert (LDA)
Rear Cross Traffic Alert (RCTA)

LDA with Automatic High Beam (AHB)

Automatic High Beam (AHB)
Lane Departure Alert (LDA)

LDA with AHB and Blind Spot Monitor (BSM)

Automatic High Beam (AHB)
Blind Spot Monitor (BSM)
- door mirrors additionally with BSM technology
Lane Departure Alert (LDA)
Rear Cross Traffic Alert (RCTA)

¹ Please consult your local Lexus Authorised Retailer for details of the Lexus Connected Services which are available in your country.

² Operates from 40 km/h.

Please note: not all options and packs are available in all countries. Also, certain options and/or packs may need to be ordered in combination with one another or cannot be ordered together. Please consult your local Lexus Authorised Retailer for further information regarding options and/or packs availability in your country.

ACCESSORIES



KEY COVER
A stylish pouch for your car's Smart Key. Made of dark grey simulated leather with decorative stitching, the Lexus logo is embossed on the reverse.



TEXTILE FLOOR MATS
Luxurious yet protective black textile floor mats. Made of sound-absorbing acuvellour, they are shaped for a perfect fit. The driver's mat has dual safety fixings to prevent it slipping.



RUBBER FLOOR MATS
The ultimate solution for your car's carpets, protecting them from muddy or wet shoes and the ingress of dirt, sand or dust. The driver's mat has dual safety fixings to hold it firmly in place.



VERTICAL CARGO NET
Enjoy added practicality and a tidy boot. The net clips on to factory-fitted hooks on the side of the luggage compartment and has two pockets for storing smaller items, while keeping them easily accessible.



HORIZONTAL CARGO NET
A convenient solution to the distraction of luggage sliding around in the boot. The net attaches to factory-fitted hooks in the boot space and is ideal for securing a bag or briefcase.



INTERIOR COMBINATIONS

ALCANTARA¹

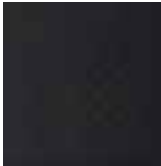

Black

SEMI-ANILINE LEATHER²



Black

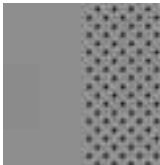

Moon Stone



Red

INLAYS³



Glass Fibre, Silver

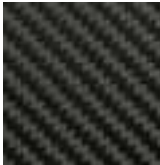

Carbon

Alcantara trim with Carbon inlays
(Carbon)



Black leather with Glass Fibre, Silver inlays
(Luxury)



Moon Stone leather with Glass Fibre, Silver inlays
(Luxury)



Red leather with Glass Fibre, Silver inlays
(Luxury)



¹ Alcantara is only available for Executive and Carbon grades.
² Semi-aniline leather is standard on Luxury grade and can be ordered as part of the leather plus pack option for the Executive and Carbon grades.
³ Carbon inlay is exclusive to Carbon grade.

EXTERIOR COLOURS

F WHITE (083)



SONIC SILVER (1J2)



MERCURY GREY (1H9)



SOLAR FLARE (4W7)



BLACK (212)¹



STARLIGHT BLACK (217)



SAPPHIRE BLUE (8X1)



RADIANT RED (3T5)



¹Solid colour

Please note: due to printing variances, actual paintwork colours may vary slightly from those illustrated.



LEXUS CARE

At Lexus, we believe in Creating Amazing. This is as true for our service and after-sales programmes as it is for the cars themselves. Throughout your vehicle's life, Lexus Care ensures a first class ownership experience, offering bespoke service and maintenance plans, each designed to provide complete satisfaction and total peace of mind.

Lexus cars are equipped with the world's most advanced technology to provide an amazing 'Omotenashi' (the Japanese spirit of hospitality) experience. Reflecting our unique approach to building cars, we also aim to treat each customer as we would a guest in our home. This world-class service philosophy has led to details like (for example) fresh flowers in handover rooms, spotlessly clean service bays, and a complimentary car wash.

After delivering each new Lexus, we see caring for your car as the equivalent of caring for you, our customer. Lexus Authorised Retailers are committed to delivering the highest level of customer satisfaction. You can catch up on the news with a cappuccino in our comfortable lounge area, or browse the internet at your leisure. Meanwhile, our technicians perform their tasks with optimum efficiency to get you back on the road with minimum interruption to your day.



LEXUS SERVICE

Lexus Service is an invitation for you to entrust the wellbeing of your Lexus to dedicated professionals and an opportunity for us to offer unparalleled levels of care. Exhaustive staff training and continuous career development programmes help provide you with the peace of mind that we're doing our utmost to ensure your Lexus stays in showroom condition.

- Professional Lexus technicians
- Genuine Lexus parts
- Lexus service history protects re-sale value
- Thorough visual safety report
- Lexus service tailored to your needs
- State-of-the-art facilities and equipment



LEXUS WARRANTY

- 3-year or 100,000 km comprehensive warranty
- 3-year surface rust and paintwork warranty
- 12-year corrosion warranty

LEXUS MOBILITY

We want to ensure that you enjoy driving your Lexus anywhere in Europe with complete peace of mind. This is why we provide free Lexus Euro Assistance 24* for the first three years of ownership. This programme ensures your mobility, to take you where you need to go. Part of this could include, for example, towing, hotel accommodation, car hire, repatriation of the vehicle and many more services should your Lexus be immobilised, stolen, or involved in a collision.

* Conditions may vary between countries. Please consult your Lexus Authorised Retailer or Repairer for details.



EXPERIENCE THE NEW RC F

Please contact your nearest Lexus Authorised Retailer for a test drive.

More about the new RC F:
www.lexus.eu/rcf
www.facebook.com/LexusEurope
www.youtube.com/LexusEurope
www.twitter.com/LexusEurope

© 2015 Lexus Europe* reserves the right to alter any details of specifications and equipment without notice. Details of specifications and equipment are also subject to change to suit local conditions and requirements. Please enquire at your local Lexus Authorised Retailer of any such changes that might be required for your area.

Note: vehicles pictured and specifications detailed in this brochure may vary from models and equipment available in your area. Vehicle body colour might differ slightly from the printed photos in this brochure.

For further information please visit our website: www.lexus.eu

Taking care of the environment is a priority for Lexus. We take many measures to ensure that during the lifecycles of our vehicles - from design, production, distribution, sales and service to end-of-life - their environmental impact is minimised. Your retailer will be happy to provide more information on end-of-life vehicle requirements.

* Lexus Europe is a division of Toyota Motor Europe NV/SA.

Printed in Europe, April 2015

