

RANGE ROVER SPORT



ABOVE AND BEYOND



RANGE ROVER SPORT 2015

Range Rover Sport was designed to be driven. The fastest Land Rover ever, its breathtaking performance is matched only by its distinctive design. Range Rover Sport also features new innovations such as InControl™ Apps. This optional feature enables you to optimize smartphone apps on the vehicle's Touch-screen. The option of a Hybrid engine is also available, that delivers powerful, responsive driving on-road and full capability off it.



DESIGNED TO BE DRIVEN

An introduction to Range Rover Sport

Page 2



SPECIFICATION

A true expression of your individuality

Page 20





Range Rover Sport; the most agile, dynamic and responsive Land Rover. Born from a relentless drive to create a contemporary yet authentic design, its streamlined front elevation and rearward sloping grille gives the vehicle immense road presence. With seductive flowing lines and styling, the sophisticated design of the vehicle is conveyed without compromising its character.



Settle back into the driver's seat of the Range Rover Sport and one thing is immediately apparent; it demands to be driven. The Sports Command Driving Position gives you an unparalleled view of the road ahead. The high centre console and a low centre of gravity make you feel connected to the road.







With over 65 years of all-terrain expertise, this vehicle has Land Rover capability at its heart. Using the latest technology such as Terrain Response® 2, the Range Rover Sport automatically recognises and optimises the settings for the current conditions, delivering unrivalled performance on and off-road.





A Land Rover's unrivalled breadth of capability has never been in question and the Range Rover Sport builds on those qualities with ease. Whether you're manoeuvring around tight corners or negotiating the traffic, the vehicle is surprisingly agile and has all the right credentials to help you manage any situation. Features like Hill Descent Control automatically help emphasise that sense of a relaxed and stress-free drive no matter what the situation.



Confident and composed, Range Rover Sport is the fastest, most responsive Land Rover ever. It has been engineered to incorporate the latest developments including new and enhanced chassis technologies. Powertrains such as the 4.4 litre LR-SDV8 Diesel deliver a staggering 740Nm. Whilst Range Rover Sport Hybrid delivers greatly reduced emissions and improved fuel economy without loss of performance. The vehicle truly is 100% Hybrid, 100% Land Rover.







Range Rover Sport has been designed and engineered to meet the needs of today. It is equally at home in the city, the back of beyond or powering down the autobahn. It has been superbly conceived and created. And those personal touches that you can include in your specifications help create a heightened sense of individuality.





Inside the Range Rover Sport the latest innovations have been incorporated to deliver complete comfort, enjoyment and exhilaration. These include an advanced Meridian™ sound system, Touch-screen with satellite and digital TV, optional rear seat entertainment with Touch-screen remote control and WhiteFire® digital wireless headphones.

The spacious rear seating package and option of two hidden seats provide improved versatility and comfort. The generous selection of interior finishes embody the individuality and understated confidence of our customers. A full-size sliding panoramic roof allows light to pour into the cabin.

Interiors shown left and above are Autobiography with Dynamic Pack in Ebony / Lunar.

WhiteFire® is a registered trademark of Unwired Technology LLC and any use of such marks by Land Rover is under licence.



Strength is nothing without control. Range Rover Sport features an advanced aluminium body and lightweight front and rear suspension. Torque Vectoring delivers more responsive, controlled cornering and handling through even the tightest of bends. And Adaptive Dynamics delivers continuous variable damping for balanced, dynamic handling. Range Rover Sport truly puts the 'S' in SUV.





Range Rover Sport's interior is meticulously fashioned to its sporting character. Superb detailing, strong elegant lines and clean surfaces combine with luxurious soft-touch finishes. Intuitively placed instruments, such as the CommandShift® 2, create a cabin that places the driver at its centre. The finest materials and an obsessive eye for detail have helped shape this comfortable yet purposeful space.

Contemporary. Beautifully designed. Flawlessly executed.

Interior shown above is Autobiography in Ebony / Lunar.
Vehicle shown right is Autobiography in Corris Grey.



NOW IT'S TIME TO CHOOSE...

Range Rover Sport offers an exclusive range of options that allow you to personalise your vehicle. The following pages take you through a logical series of steps to make it a true expression of your individuality. You have several choices: from selecting your engine and model to exterior and interior colours, wheels, finishes and those detailed touches that define your style.

If you'd like to bring your options to life, go to our online configurator at landrover.com

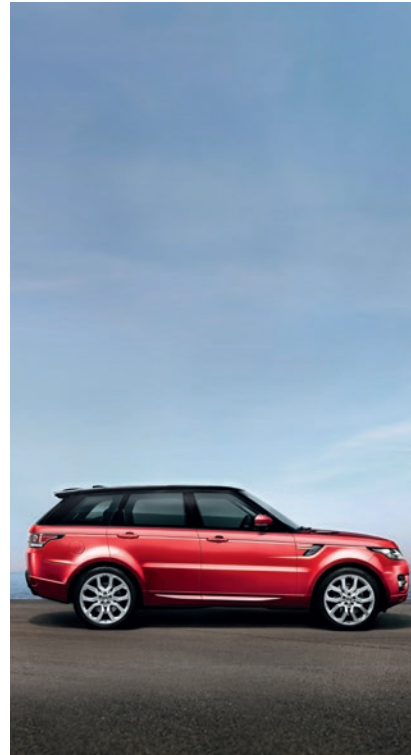

Hybrid

Page 22

The world's first Diesel Hybrid SUV.

Step 1

Choose your engine

Page 26

You can select from a powerful range of petrol or diesel engines including the new hybrid diesel engine.

Step 2

Choose your model

Page 28

Compare the standard features on each model.

Step 3

Choose your colour

Page 32

There's a wide range on offer to enable you to express yourself.

Step 4

Choose your wheels

Page 36

There's a range of styles, each one designed to complement the bold exterior.



Step 5

Choose your interior

Page 38

Carefully selected colours complemented by the finest metals and real wood veneers. You can personalise your own interior space.

Key Features

Page 58

The latest innovations that make your vehicle a pleasure to drive.

Technical Details

Page 62

Technical information and data for dimensions, performance and specifications.

Accessories

Page 64

Additional accessories can enhance your personal requirements.

RANGE ROVER SPORT HYBRID

Range Rover Sport Hybrid is the first diesel SUV of its kind in the world. It has been designed and engineered to deliver class-leading capability and versatility. By fully integrating the hybrid technologies into the chassis, nothing has been lost in ground clearance, approach and departure angles or the 850mm wading depth.

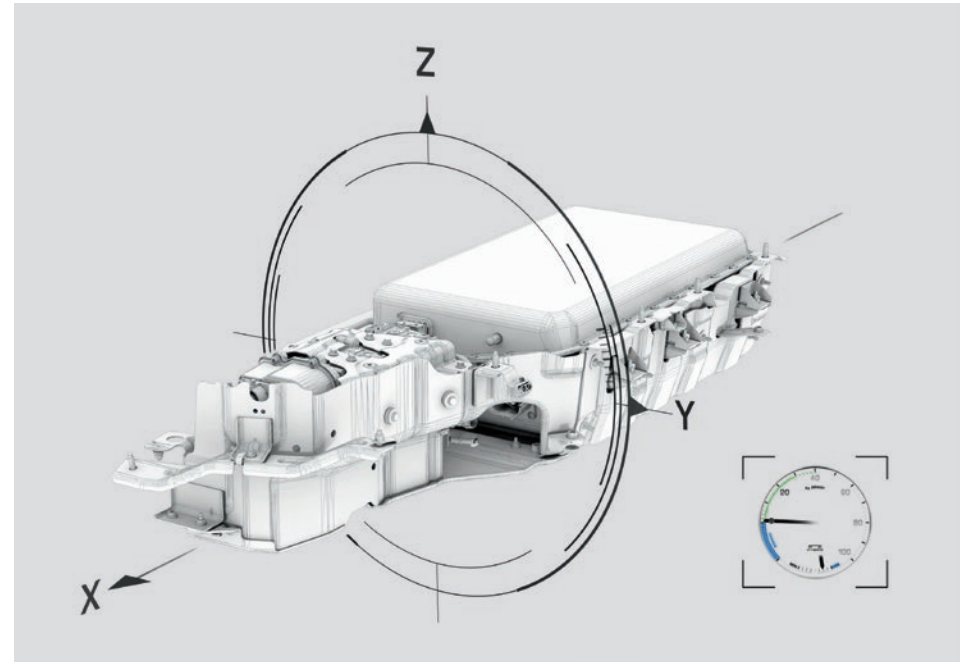

Range Rover Sport Hybrid has been tested on the most demanding terrains, rigs and under the same extremes as every Land Rover. Whilst nothing has been lost in the responsiveness of the drive, hybrid technologies deliver impressive efficiencies. The 3.0L LR-SDV6 Diesel engine with a 35kW electric motor generates an impressive 700Nm of torque resulting in the same performance as the LR-SDV8 Diesel but with 13% lower (25g/km less) CO₂ emissions when compared to the LR-TDV6 engine at 169g/km.

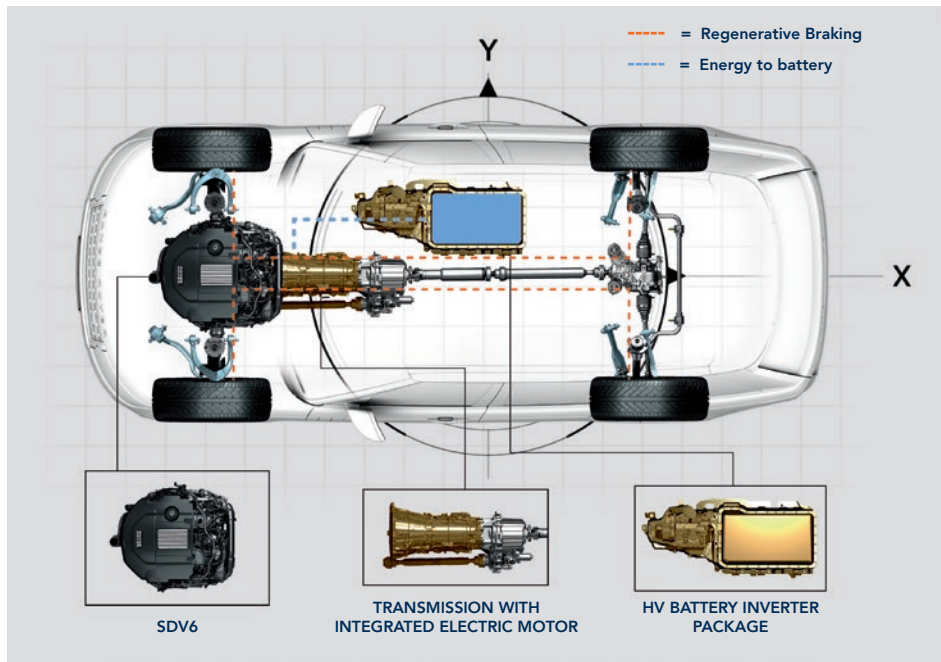

Innovative engineering ensures the transmission of energy between battery and engine is seamless. This energy is created by the Regenerative Braking process, which captures and stores kinetic energy in the battery, normally lost through braking. This is then used to power the electric motor and ensures that torque is instantly available on demand so the vehicle maintains unrivalled breadth of capability.

RANGE ROVER SPORT HYBRID

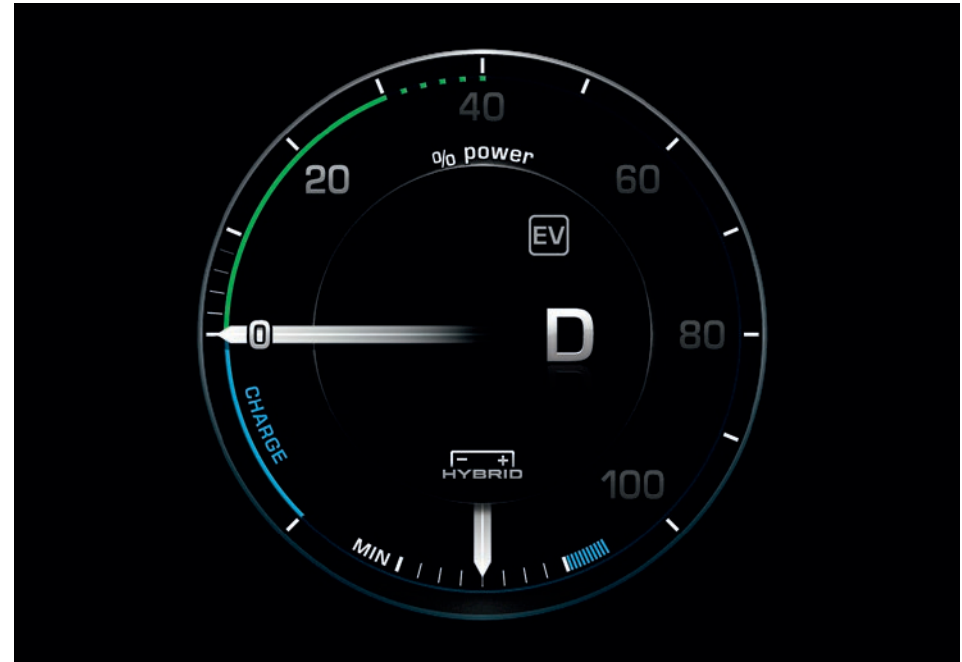

Select from four Hybrid driving modes to tailor the vehicle's performance to your requirements giving the most dynamic model in Land Rover portfolio an extra dimension.



Electric Vehicle (EV) On Mode: Optimises hybrid battery power and is whisper quiet whilst travelling around town or peaceful villages.



EV Off Mode: Enables the vehicle's default setting where the hybrid system selects the most efficient combination of diesel and electric power to meet the power and torque required.



Sport Mode: Gives full access to the vehicle's comparable LR-SDV8 performance. The throttle response becomes more immediate with torque triggered from less pedal pressure, ideal for overtaking when it is safe to do so.



Auto Stop/Start: Increases charging opportunities as this option means the engine runs continuously, inhibiting the Stop/Start system.



Attention to detail is at the very heart of Land Rover. That's why even the alloy wheels on Range Rover Sport Hybrid have been designed for increased efficiency. The design features spokes that are aerodynamically shaped so, as they move through the air, they require less power to keep them moving.

To finish, the vehicle is specified with a unique Hybrid badge that is located on the side vent.

STEP 1 CHOOSE YOUR ENGINE



DRIVELINE, ENGINE PERFORMANCE AND FUEL ECONOMY

The improved range of petrol and diesel engines, along with the new hybrid engine, use the very latest technology. In fact, coupled with lightweight all-aluminium technology and an eight-speed transmission, these engines deliver greatly improved fuel efficiency and lower CO₂ emissions. However, nothing has been lost in performance. For instance, the 5.0 litre LR-V8 Supercharged goes from 0-100kph in just 5.3 seconds. The 3.0 litre LR-TDV6 diesel features intelligent Stop/Start technology (market dependent) that automatically shuts down the engine at rest and starts again as soon as you lift your foot off the brake.

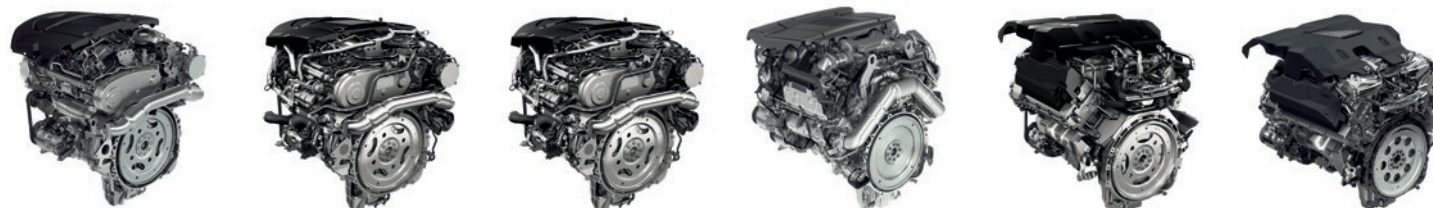

		3.0L TDV6 DIESEL	3.0L SDV6 DIESEL	3.0L SDV6 HYBRID DIESEL*	4.4L SDV8 DIESEL	3.0L V6 PETROL	5.0L V8 SUPERCHARGED PETROL
Driveline		Four Wheel Drive (4WD)	Four Wheel Drive (4WD)	Four Wheel Drive (4WD)	Four Wheel Drive (4WD)	Four Wheel Drive (4WD)	Four Wheel Drive (4WD)
Power (kW/PS)		190 / 258	215 / 292	250 / 340**	250 / 339	250 / 340	375 / 510
Torque (Nm)		600	600	700**	740	450	625
Maximum torque (rpm)		2,000	2,000	1,500 – 3,000**	1,750 – 3,000	3,500 – 5,000	2,500 – 5,500
Capacity (cc)		2,993	2,993	2,993	4,367	2,995	4,999.7
No. of cylinders		6	6	6	8	6	8
Cylinder layout		Longitudinal V6	Longitudinal V6	Longitudinal V6	Longitudinal V8	Longitudinal V6	Longitudinal V8
FUEL ECONOMY							
Urban	l/100km (mpg)	8.3 (34.0) / 9.8 (28.8) [†]	8.7 (32.5) / 9.8 (28.8) [†]	6.7 (42.0)	11.5 (24.6)	14.0 (20.2) / 15.4 (18.3) [†]	18.3 (15.4) / 20.5 (13.8) [†]
Extra Urban	l/100km (mpg)	6.7 (42.2) / 6.8 (41.5) [†]	6.8 (41.5) / 6.8 (41.5) [†]	6.3 (45.0)	7.6 (37.2)	8.8 (32.1) / 8.9 (31.7) [†]	9.7 (29.1) / 10.0 (28.3) [†]
Combined	l/100km (mpg)	7.3 (38.7) / 7.9 (35.8) [†]	7.5 (37.7) / 7.5 (35.8) [†]	6.4 (44.1)	8.7 (32.5)	10.7 (26.4) / 11.3 (25.0) [†]	12.8 (22.1) / 13.8 (20.5) [†]
CO ₂ Urban emissions	g/km	218 / 258 [†]	230 / 258 [†]	177	306	326 / 359 [†]	426 / 478 [†]
CO ₂ Extra Urban emissions	g/km	177 / 180 [†]	180 / 180 [†]	165	203	205 / 208 [†]	226 / 233 [†]
CO ₂ Combined emissions	g/km	194 / 209 [†]	199 / 209 [†]	169	229	249 / 264 [†]	298 / 321 [†]

*Not available in all markets **When combined with electric motor. [†]Without Intelligent Stop/Start technology.

Fuel consumption figures: the results given here do not express or imply any guarantee of the fuel consumption of any particular vehicle with which this information may be supplied. Vehicles are not individually tested and there are inevitable differences between individual vehicles of the same model. The vehicle may also incorporate particular modifications. Furthermore, the driver's style and road traffic conditions, as well as the extent to which the vehicle has been driven and the standard of maintenance, will affect its fuel consumption. Low fuel warning at 9 litres approximately.

Vehicle shown left is Autobiography in Firenze Red.

Visit landrover.com for more information.

STEP 2 CHOOSE YOUR MODEL



MODELS BY ENGINE

	S	SE	HSE	HSE WITH DYNAMIC PACK	AUTOBIOGRAPHY	AUTOBIOGRAPHY WITH DYNAMIC PACK
3.0L TDV6 Diesel	■	■	■			
3.0L SDV6 Diesel	■	■	■	■	■	■
3.0L SDV6 Hybrid Diesel*			■	■	■	■
4.4L SDV8 Diesel			■	■	■	■
3.0L V6 Petrol	■	■	■	■	■	■
5.0L V8 Supercharged Petrol			■	■	■	■

*Not available in all markets.

Vehicle shown left is Autobiography in Firenze Red.

Visit landrover.com for more information.

STEP 2 CHOOSE YOUR MODEL – CHOICES

Each model has a choice of engines and unique features. This guide will help you to select your ideal Range Rover Sport. On the following pages you'll see the standard features for each model.

RANGE ROVER SPORT S / SE*



- Grille in Dark Atlas with Gloss Black surround
- Fender vent with Dark Atlas fingers, Atlas mesh and Gloss Black surround
- Body coloured upper mirror caps
- Tow eye covers in Dark Atlas
- 19 inch five split-spoke 'Style 501' (TDV6 only)
- 20 inch five split-spoke 'Style 520' (Standard on SE with SDV6)
- Seats for S model in Cloth
- Seats for SE model in Grained leather.

RANGE ROVER SPORT HSE



- Grille in Atlas with Gloss Black surround
- Fender vent with Atlas fingers, Atlas mesh and Gloss Black surround
- Body coloured upper mirror caps
- Fog lamp surrounds and tow eye covers in Atlas
- 20 inch five split-spoke 'Style 520'
- Seats in Oxford Perforated leather as standard
- Available with Hybrid.

RANGE ROVER SPORT HSE WITH DYNAMIC PACK



- Grille in Gloss Black painted mesh with Gloss Black surround
- Fender vent with Gloss Black fingers, Atlas mesh and Gloss Black surround
- Gloss Black upper mirror caps
- Fog lamp surrounds and tow eye covers in Gloss Black
- Tailgate finisher in Gloss Black
- 21 inch five split-spoke 'Style 507' with Diamond Turned finish
- 20 inch Red Brembo™ branded brake calipers
- Performance Enhancement (increase in Top Speed)
- Seats in Oxford Perforated leather as standard
- Additional Dynamic pack interior colourways
- Available with Hybrid.

RANGE ROVER SPORT AUTOBIOGRAPHY



- Grille in Atlas with Gloss Black surround
- Fender vent with Atlas fingers, Atlas mesh and Gloss Black surround
- Body coloured upper mirror caps
- Body coloured side sills and lower bumper corners
- Fog lamp surrounds and tow eye covers in Atlas
- 21 inch five split-spoke 'Style 507'
- Seats in Oxford Perforated leather with Autobiography Pattern as standard
- Available with Hybrid.

RANGE ROVER SPORT AUTOBIOGRAPHY WITH DYNAMIC PACK



- Grille in Gloss Black painted mesh with Gloss Black surround
- Fender vent with Gloss Black fingers, Atlas mesh and Gloss Black surround
- Gloss Black upper mirror caps
- Unique design of front and rear bumper corners in body colour
- Body coloured side sills
- Fog lamp surrounds and tow eye covers in Gloss Black
- Tailgate finisher in Gloss Black
- 21 inch five split-spoke 'Style 505'
- 20 inch Red Brembo™ branded brake calipers
- Performance Enhancement (increase in Top Speed)
- Seats in Oxford Perforated leather with Autobiography Pattern as standard
- Additional Dynamic pack interior colourways
- Available with Hybrid.

STEP 3 CHOOSE YOUR COLOUR

Body and Roof Colour



Optional Roof Colour

Contrast Indus Silver



Contrast Corris Grey



Contrast Santorini Black



*The availability of exterior paint colours varies by model and by time of year.
Please contact your nearest Land Rover Dealer for further details.

Body and Roof Colour

Firenze Red (Metallic) Chile* (Premium Metallic) Aintree Green (Metallic) Loire Blue (Metallic) Mariana Black (Premium Metallic) Santorini Black (Metallic) Barossa* (Premium Metallic) Havana (Premium Metallic) Barolo Black (Premium Metallic)



Optional Roof Colour

Contrast Indus Silver



Contrast Corris Grey



Contrast Santorini Black

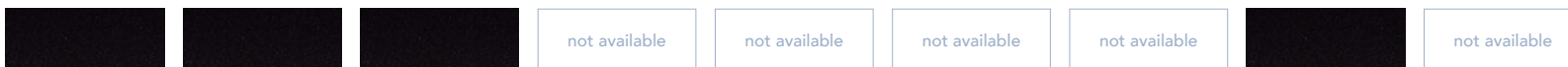

Visit landrover.com for more information.

STEP 3 CHOOSE YOUR COLOUR – STEALTH PACK



Personalising the exterior

For an even more striking effect, Range Rover Sport HSE with Dynamic Pack and Autobiography with Dynamic Pack can be further personalised with the optional Stealth Pack. Emphasising the assertive, confident stance of the vehicle, the Stealth Pack makes Range Rover Sport your own.



Stealth Pack is available in all exterior colour options and includes Satin Black exterior accents such as; front grille and grille surround, RANGE ROVER lettering on bonnet and tailgate, upper mirror caps, tow eye cover. In addition the pack comes with darkened front and rear headlamps and a choice of 21 inch or 22 inch wheels in Satin Black finish.

STEP 4 CHOOSE YOUR WHEELS



19 INCH FIVE SPLIT-SPOKE
'STYLE 501'*



19 INCH FIVE SPLIT-SPOKE
SATIN DARK GREY FINISH
'STYLE 501'*



20 INCH FIVE SPLIT-SPOKE
'STYLE 520'*



21 INCH FIVE SPLIT-SPOKE
'STYLE 507'*



21 INCH FIVE SPLIT-SPOKE
DIAMOND TURNED FINISH
'STYLE 507'*



21 INCH FIVE SPLIT-SPOKE
'STYLE 505'



21 INCH SIX-SPOKE
DIAMOND TURNED FINISH
'STYLE 602'
(HYBRID ONLY)



21 INCH SIX-SPOKE
'STYLE 602'
(HYBRID ONLY)



21 INCH NINE SPOKE
SATIN BLACK FINISH
'STYLE 901'
(STEALTH PACK ONLY)



22 INCH FIVE SPLIT-SPOKE
'STYLE 504'



22 INCH FIVE SPLIT-SPOKE
'STYLE 508'



22 INCH FIVE SPLIT-SPOKE
SATIN BLACK FINISH
'STYLE 508'
(STEALTH PACK ONLY)

STEP 5 CHOOSE YOUR INTERIOR



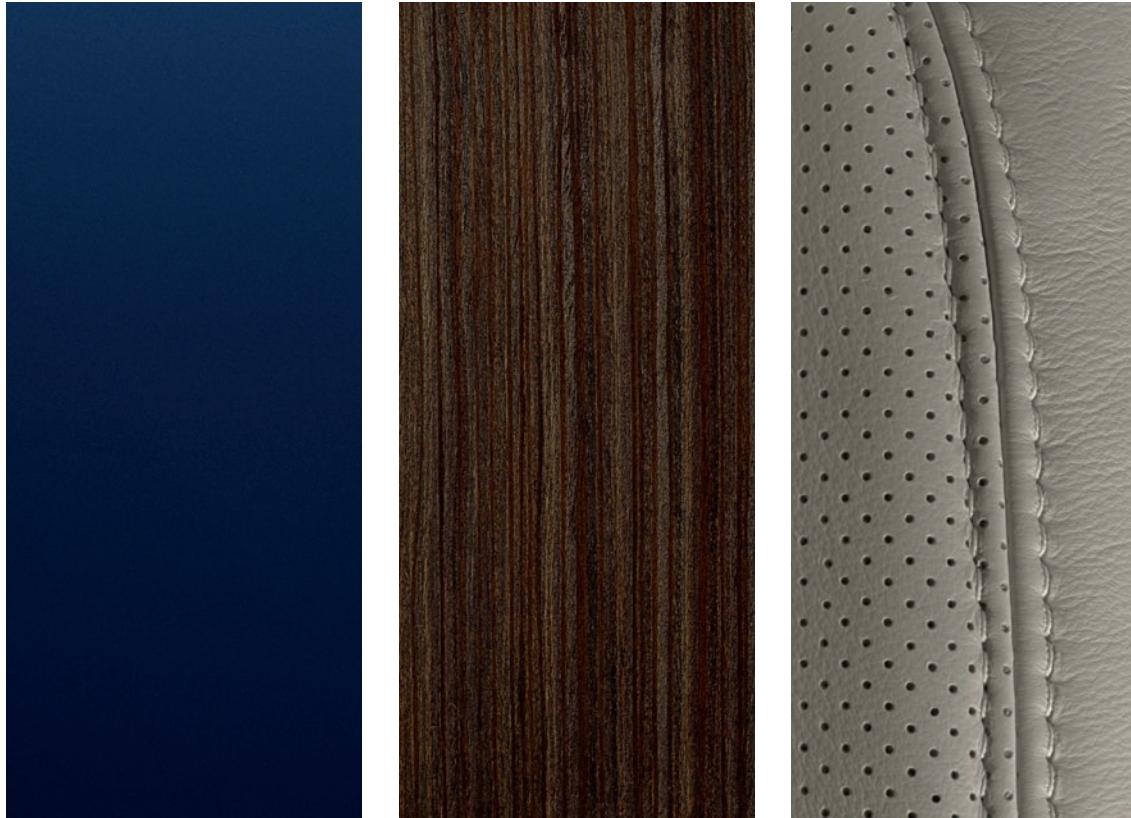

Contemporary. Beautifully designed. Flawlessly executed. The interior of each and every Range Rover Sport defines modern living. The strong architectural lines of the interior are balanced by soft lighting and the choice of colourways available. The fit and finish has been taken to another level: the use of leather and metal truly complements the sporty styling.

STEP 5 CHOOSE YOUR INTERIOR – LEATHER FINISHES



The softest of leathers, the most meticulous of finishes

The interior is upholstered in the finest natural materials. The warmth of wood veneers, superb metal finishes and soft leathers combine to create a sense of home. The attention to detail is everywhere you look and in everything you touch. The type of leather is determined by model choice as outlined in the following pages.

STEP 5 CHOOSE YOUR INTERIOR – TRIM FINISHER CHOICES



DARK BRUSHED ALUMINIUM FINISHER

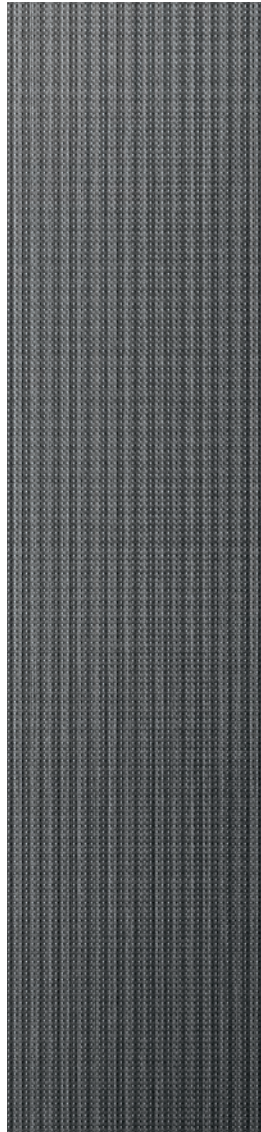

MICRO MESH ALUMINIUM FINISHER

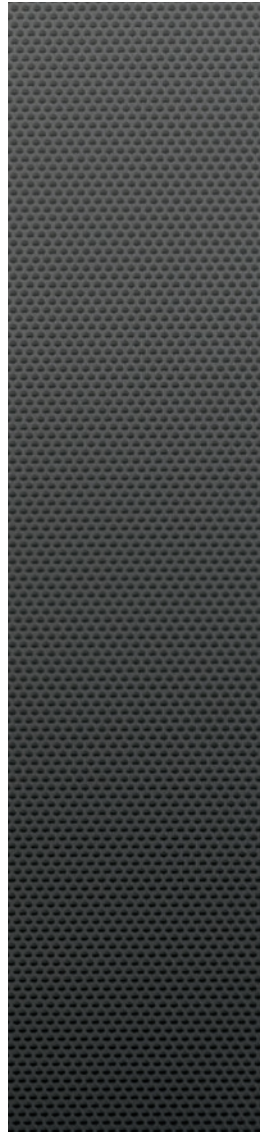

SPORT TEXTURED ALUMINIUM FINISHER



DARK ENGINE TURNED ALUMINIUM FINISHER



SHADOW ZEBRANO WOOD VENEER



DARK GREY OAK WOOD VENEER

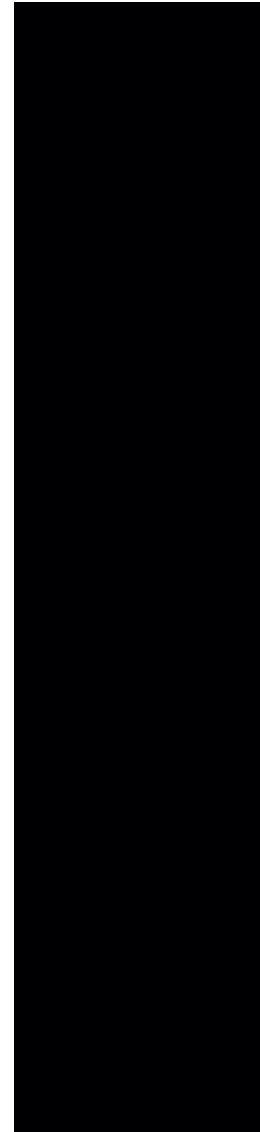

GRAND BLACK WOOD VENEER

STEP 5 CHOOSE YOUR INTERIOR – INTERIOR SEAT OPTIONS



5 Seats

The seat configuration has been intelligently redesigned to accommodate the lines of the roofline. It's light and spacious, ensuring everyone has a relaxed and comfortable journey. There is generous leg, shoulder and head room throughout the contemporary cabin.





























5+2 Seating



























The 5+2 arrangement has two seats stowed under the floor of the luggage compartment that have been designed for occasional use, enabling the vehicle to accommodate up to seven occupants.*

*The third row seats are not suitable for use by children who require child seats or booster seats.

COLOUR AND TRIM MATRIX

COLOURWAYS		EBONY/LUNAR (page 47)			ESPRESSO/ALMOND (page 48)			EBONY/CIRRUS (page 49)			ESPRESSO/IVORY (page 50)		
INTERIOR COLOUR													
Seat colour		Ebony	Lunar	Ebony/ Lunar	Espresso	Almond	Espresso/ Almond	Ebony	Cirrus	Ebony/ Cirrus	Espresso	Ivory	Espresso/ Ivory
Carpet		Ebony			Espresso			Ebony			Espresso		
MODEL													
S (Cloth)		○	–	–	–	–	–	–	–	–	–	–	–
SE (Grained leather)		○	–	–	–	○	–	–	○	–	–	–	–
HSE (Oxford Perforated leather)		○	○	–	○	○	–	○	○	–	○	○	–
HSE with Dynamic Pack (Oxford Perforated leather)		○	○	–	○	○	–	○	○	–	○	○	–
Autobiography (Oxford Perforated leather with Autobiography Pattern)		○	○	○	○	○	○	○	○	○	○	○	○
Autobiography with Dynamic Pack (Oxford Perforated leather with Autobiography Pattern)		○	○	○	○	○	○	○	○	○	○	○	○
TRIM FINISHER													
 Dark Brushed Aluminium finisher		○	–	–	–	○	–	–	○	–	–	–	–
 Micro Mesh Aluminium finisher		○	–	–	○	○	–	○	○	–	○	○	–
 Sport Textured Aluminium finisher		○	○	–	○	○	–	○	○	–	○	○	–
 Dark Engine Turned Aluminium finisher		○	○	○	○	○	○	○	○	○	○	○	○
 Shadow Zebrano Wood Veneer		–	–	–	○	○	○	–	–	–	○	○	○
 Dark Grey Oak Wood Veneer		○	○	○	–	–	–	○	○	○	–	–	–
 Grand Black Wood Veneer		○	○	○	○	○	○	○	○	○	○	○	○
EXTERIOR COLOUR													
 Fuji White		○	○	○	○	○	○	○	○	▲	○	○	○
 Yulong White*		○	○	▲	○	○	○	▲	▲	▲	○	○	○
 Aleutian Silver		○	○	○	○	○	○	○	▲	○	○	○	○
 Indus Silver		▲	○	○	○	○	○	▲	○	○	○	○	○
 Kaikoura Stone		○	○	○	▲	○	○	○	○	○	▲	○	▲
 Aruba		○	○	○	▲	○	○	○	○	○	▲	○	○
 Chablis		○	○	○	○	○	○	○	○	○	○	○	○
 Scotia Grey		○	○	○	○	○	○	○	○	○	○	○	○
 Corris Grey		○	○	▲	○	○	○	○	○	○	○	○	○
 Causeway Grey		○	○	▲	○	○	○	▲	○	▲	○	○	○
 Montalcino Red		○	○	○	○	○	○	○	○	○	○	○	○
 Firenze Red		○	○	○	○	○	○	○	○	○	○	○	○
 Chile*		▲	○	○	○	○	○	▲	○	○	○	○	○
 Aintree Green		○	○	○	○	○	○	○	○	○	○	▲	○
 Loire Blue		○	○	○	○	○	○	○	○	○	○	○	○
 Mariana Black		○	○	○	○	○	○	○	▲	○	○	○	○
 Barossa*		○	○	○	○	▲	○	○	○	○	○	○	○
 Santorini Black		○	▲	○	○	○	○	○	▲	○	○	○	○
 Havana		○	▲	○	○	○	▲	○	○	○	○	○	▲
 Barolo Black		○	○	○	○	○	○	○	○	○	○	▲	○

*The availability of exterior paint colours varies by model and by time of year. Please contact your nearest Land Rover Dealer for further details.
▲Combination is Designer's Choice ○Combination is Available – Not Available.

COLOURWAYS	EBONY/IVORY (page 51)			EBONY/TAN (page 52)		EBONY/PIMENTO (page 53)		ESPRESSO/ IVORY/TAN (page 54)	ESPRESSO/IVORY/ SAVANNAH (page 55)	EBONY/LUNAR/ CIRRUS (page 56)	EBONY/LUNAR/ SAVANNAH (page 57)
INTERIOR COLOUR											
Seat colour	Ebony	Ivory	Ebony/ Ivory	Tan	Ebony/ Tan	Pimento	Ebony/ Pimento	Espresso/Ivory/ Tan	Espresso/Ivory/ Savannah	Ebony/Lunar/ CIRRUS	Ebony/Lunar/ Savannah
Carpet	Ebony			Ebony		Ebony		Espresso	Espresso	Ebony	Ebony
MODEL											
S (Cloth)	-	-	-	-	-	-	-	-	-	-	-
SE (Grained leather)	-	-	-	-	-	-	-	-	-	-	-
HSE (Oxford Perforated leather)	o	o	-	-	-	-	-	-	-	-	-
HSE with Dynamic Pack (Oxford Perforated leather)	o	o	-	o	-	o	-	-	-	-	-
Autobiography (Oxford Perforated leather with Autobiography Pattern)	o	o	o	-	-	-	-	o	o	-	-
Autobiography with Dynamic Pack (Oxford Perforated leather with Autobiography Pattern)	o	o	o	o	o	o	o	o	o	o	o
TRIM FINISHER											
 Dark Brushed Aluminium finisher	-	-	-	-	-	-	-	-	-	-	-
 Micro Mesh Aluminium finisher	o	o	-	-	-	-	-	-	-	-	-
 Sport Textured Aluminium finisher	o	o	-	o	-	o	-	-	-	-	-
 Dark Engine Turned Aluminium finisher	o	o	o	o	o	o	o	o	o	o	o
 Shadow Zebrano Wood Veneer	o	o	o	-	-	-	-	o	o	-	-
 Dark Grey Oak Wood Veneer	-	-	-	o	o	o	o	-	-	o	o
 Grand Black Wood Veneer	o	o	o	o	o	o	o	o	o	o	o
EXTERIOR COLOUR											
 Fuji White	o	o	o	▲	o	o	o	▲	o	▲	o
 Yulong White*	o	o	o	▲	▲	▲	o	o	o	o	▲
 Aleutian Silver	o	o	o	o	o	o	o	o	o	▲	o
 Indus Silver	o	o	o	o	o	o	o	o	o	o	o
 Kaikoura Stone	o	o	o	o	o	o	o	o	▲	o	o
 Aruba	o	▲	o	o	o	o	▲	▲	▲	o	o
 Chablis	o	o	o	o	o	o	o	o	▲	▲	▲
 Scotia Grey	o	o	o	o	o	o	o	o	o	o	o
 Corris Grey	o	o	o	▲	o	o	▲	o	o	▲	▲
 Causeway Grey	o	o	▲	o	▲	▲	o	o	o	▲	▲
 Montalcino Red	o	o	o	-	-	o	▲	-	o	o	-
 Firenze Red	▲	o	o	-	-	o	▲	o	-	o	-
 Chile*	o	o	o	o	o	o	o	o	-	o	-
 Aintree Green	o	o	o	o	o	o	o	o	o	o	o
 Loire Blue	o	▲	o	o	o	o	o	o	o	o	o
 Mariana Black	o	▲	o	o	o	o	o	o	o	o	o
 Santorini Black	o	▲	▲	o	▲	▲	o	o	o	o	▲
 Barossa*	o	o	o	o	o	o	o	-	-	-	-
 Havana	▲	o	o	▲	o	o	o	o	▲	o	o
 Barolo Black	o	o	o	o	o	o	▲	o	o	o	o

*The availability of exterior paint colours varies by model and by time of year. Please contact your nearest Land Rover Dealer for further details.

▲ Combination is Designer's Choice o Combination is Available - Not Available.

The above table is designed as a guide. Please contact your nearest Land Rover Dealer for more information.

STEP 5 CHOOSE YOUR INTERIOR – CHOICES

Colour choices

Each interior comes in up to three colour combinations. You can now use this section to place your chosen colourway within the vehicle to personalise your cabin. A choice of trim finishers are also available.



COLOURWAYS	① INSTRUMENT PANEL UPPER	② INSTRUMENT PANEL MID/ CENTRE CUBBY LID	③ DOOR TOP ROLL	④ DOOR ARMREST	⑤ DOOR LOWER
Ebony/Lunar	Ebony	Lunar	Lunar	Lunar	Ebony
Espresso/Almond	Espresso	Almond	Almond	Almond	Almond
Ebony/Cirrus	Ebony	Cirrus	Cirrus	Cirrus	Ebony
Espresso/Ivory	Espresso	Ivory	Ivory	Ivory	Ivory
Ebony/Ivory	Ebony	Ivory	Ivory	Ivory	Ebony
Ebony/Tan	Ebony	Tan	Tan	Tan	Ebony
Ebony/Pimento	Ebony	Pimento	Pimento	Pimento	Ebony
Espresso/Ivory/Tan	Espresso	Ivory	Ivory	Tan	Ivory
Espresso/Ivory/Savannah	Espresso	Ivory	Ivory	Savannah	Ivory
Ebony/Lunar/Cirrus	Ebony	Lunar	Lunar	Cirrus	Ebony
Ebony/Lunar/Savannah	Ebony	Lunar	Lunar	Savannah	Ebony

Ebony / Lunar (available on S, SE, HSE, HSE with Dynamic Pack, Autobiography and Autobiography with Dynamic Pack)



Interior Shown:
HSE interior in Ebony/Lunar,
with Ebony seats and Dark Brushed
Aluminium finisher.

Seat Choices



Ebony



Lunar



Ebony/Lunar

Trim Finisher Choices



Dark Brushed Aluminium finisher



Micro Mesh Aluminium finisher



Sport Textured Aluminium finisher



Dark Engine Turned Aluminium finisher



Grand Black Wood Veneer



Dark Grey Oak Wood Veneer

This interior is available in:
Cloth on S models
Grained leather on SE models
Oxford leather on HSE models
Oxford leather with Autobiography Pattern
on Autobiography models.

For specific colourway options please refer to page 44.

STEP 5 CHOOSE YOUR INTERIOR – CHOICES

Espresso / Almond (available on SE, HSE, HSE with Dynamic Pack, Autobiography and Autobiography with Dynamic Pack)



Interior shown:
Autobiography interior in
Espresso/Almond, with Espresso/
Almond seats and Shadow
Zebrano Wood Veneer.

Seat Choices



Espresso



Almond



Espresso/Almond

Trim Finisher Choices



Dark Brushed Aluminium finisher



Micro Mesh Aluminium finisher



Sport Textured Aluminium finisher



Dark Engine Turned Aluminium finisher



Grand Black Wood Veneer



Shadow Zebrano Wood Veneer

This interior is available in:
Grained leather on SE models
Oxford leather on HSE models
Oxford leather with Autobiography Pattern
on Autobiography models.

For specific colourway options please refer to page 44.

Ebony / Cirrus (available on SE, HSE, HSE with Dynamic Pack, Autobiography and Autobiography with Dynamic Pack)



Interior shown:
HSE interior in Ebony/Cirrus,
with Ebony seats and
Grand Black Wood Veneer.

Seat Choices



Ebony



Cirrus



Ebony/Cirrus

Trim Finisher Choices



Dark Brushed Aluminium finisher

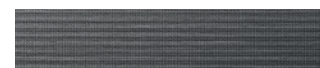

Micro Mesh Aluminium finisher



Sport Textured Aluminium finisher



Dark Engine Turned Aluminium finisher



Grand Black Wood Veneer



Dark Grey Oak Wood Veneer

This interior is available in:
Grained leather on SE models
Oxford leather on HSE models
Oxford leather with Autobiography Pattern
on Autobiography models.

For specific colourway options please refer to pages 44.

STEP 5 CHOOSE YOUR INTERIOR – CHOICES

Espresso / Ivory (available on HSE, HSE with Dynamic Pack, Autobiography and Autobiography with Dynamic Pack)



Interior shown:
Autobiography interior in
Espresso/Ivory, with Espresso/
Ivory seats and Micro Mesh
Aluminium finisher.

Seat Choices



Espresso



Ivory



Espresso/Ivory

Trim Finisher Choices



Micro Mesh Aluminium finisher



Sport Textured Aluminium finisher



Dark Engine Turned Aluminium finisher



Grand Black Wood Veneer



Shadow Zebrano Wood Veneer

This interior is available in:
Oxford leather on HSE models
Oxford leather with Autobiography Pattern
on Autobiography models.

For specific colourway options please refer to page 44.

Ebony / Ivory (HSE, HSE with Dynamic Pack, Autobiography and Autobiography with Dynamic Pack)



Interior shown:
Autobiography interior in
Ebony/Ivory, with Ebony/Ivory
seats and Micro Mesh
Aluminium finisher.

Seat Choices



Ebony



Ivory



Ebony/Ivory

Trim Finisher Choices

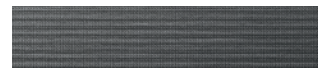

Micro Mesh Aluminium finisher



Sport Textured Aluminium finisher



Dark Engine Turned Aluminium finisher



Grand Black Wood Veneer



Shadow Zebrano Wood Veneer

This interior is available in:
Oxford leather on HSE models
Oxford leather with Autobiography Pattern
on Autobiography models.
For specific colourway options please refer to page 45.

STEP 5 CHOOSE YOUR INTERIOR – CHOICES

Ebony / Tan (available on HSE with Dynamic Pack and Autobiography with Dynamic Pack)



Interior shown:
Autobiography with Dynamic Pack
interior in Ebony/Tan, with
Ebony/Tan seats and Dark Grey
Oak Wood Veneer.

Seat Choices



Tan



Ebony/Tan*

Trim Finisher Choices



Sport Textured Aluminium finisher



Dark Engine Turned Aluminium finisher



Dark Grey Oak Wood Veneer



Grand Black Wood Veneer

This interior is available in:
Oxford leather on HSE models
Oxford leather with Autobiography Pattern
on Autobiography models.

For specific colourway options please refer to pages 45.

Ebony / Pimento (available on HSE with Dynamic Pack and Autobiography with Dynamic Pack)



Interior shown:
Autobiography with Dynamic Pack
interior in Ebony/Pimento, with
Ebony/Pimento seats and Dark
Engine Turned Aluminium finisher.

Seat Choices



Pimento



Ebony/Pimento*

Trim Finisher Choices



Sport Textured Aluminium finisher

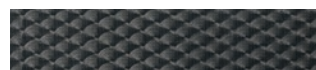

Dark Engine Turned Aluminium finisher



Dark Grey Oak Wood Veneer



Grand Black Wood Veneer

This interior is available in:
Oxford leather on HSE models
Oxford leather with Autobiography pattern
on Autobiography models.

For specific colourway options please refer to pages 45.

*Only available on Autobiography with Dynamic Pack models.

STEP 5 CHOOSE YOUR INTERIOR – CHOICES

Espresso / Ivory / Tan (available on Autobiography and Autobiography with Dynamic Pack only)



Interior shown:
Autobiography interior in
Espresso/Ivory/Tan, with Espresso/
Ivory/Tan seats and Shadow
Zebrano Wood Veneer.

Seat Choices



Espresso/Ivory/Tan

Trim Finisher Choices



Dark Engine Turned Aluminium finisher



Shadow Zebrano Wood Veneer



Grand Black Wood Veneer

This interior is available in:
Oxford leather with Autobiography Pattern
on Autobiography models.

For specific colourways please refer to page 45.

Espresso / Ivory / Savannah (available on Autobiography and Autobiography with Dynamic Pack only)

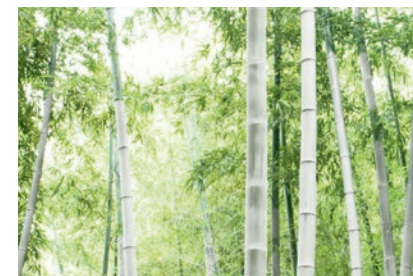

Interior shown:
Autobiography interior in Espresso/Ivory/Savannah, with Espresso/Ivory/Savannah seats and Dark Engine Turned Aluminium finisher.

Seat Choices



Espresso/Ivory/Savannah

Trim Finisher Choices



Dark Engine Turned Aluminium finisher



Grand Black Wood Veneer



Shadow Zebrano Wood Veneer

This interior is available in:
Oxford leather with Autobiography Pattern
on Autobiography models.
For specific colourways please refer to page 45.

STEP 5 CHOOSE YOUR INTERIOR – CHOICES

Ebony / Lunar / Cirrus (available on Autobiography with Dynamic Pack only)



Interior shown:
Autobiography with Dynamic Pack
interior in Ebony/Lunar/Cirrus,
with Ebony/Lunar/Cirrus seats
and Dark Grey Oak Wood Veneer.

Seat Choices



Ebony/Lunar/Cirrus

Trim Finisher Choices



Dark Engine Turned Aluminium finisher



Dark Grey Oak Wood Veneer



Grand Black Wood Veneer

This interior is available in:
Oxford leather with Autobiography Pattern
on Autobiography models.

For specific colourways please refer to page 45.

Ebony / Lunar / Savannah (available on Autobiography with Dynamic Pack only)



Interior shown:
Autobiography with Dynamic Pack
interior in Ebony/Lunar/Savannah,
with Ebony/Lunar/Savannah seats
and Dark Grey Oak Wood Veneer.

Seat Choices



Ebony/Lunar/Savannah

Trim Finisher Choices



Dark Engine Turned Aluminium finisher



Grand Black Wood Veneer



Dark Grey Oak Wood Veneer

This interior is available in:
Oxford leather with Autobiography Pattern
on Autobiography models.

For specific colourways please refer to page 45.

KEY FEATURES





Terrain Response® 2

Next generation Terrain Response® 2 is designed to monitor driving conditions and automatically optimises the vehicle's settings to suit the terrain. This gives you the ultimate in ride comfort on all surfaces including grass/gravel/snow, mud/ruts, sand and rock. And even if it is not in auto mode, it will let you know if you should select low range and off-road ride height.



Eight-speed Automatic Transmission with CommandShift® 2

All petrol and diesel engines in Range Rover Sport are paired with the advanced electronically controlled eight-speed automatic gearbox which has been tuned by Land Rover engineers to combine silky smooth shifting with exceptionally rapid responses and outstanding fuel economy. With eight closely-spaced ratios, gear changes are almost imperceptible, with each shift completed in just 200 milliseconds.



Electric Power Assisted Steering (EPAS)

The Electric Power Assisted Steering (EPAS) system helps to deliver accurate, consistent steering and agile cornering. Power assistance is speed-sensitive so the steering is light and responsive at lower speeds and firmer at higher speeds.



Dynamic Response

Dynamic Response transforms vehicle handling through hydraulic roll and yaw control, optimising on road performance and passenger comfort. The system works in addition to Adaptive Dynamics which monitors the vehicle's movements over 500 times a second, reacting to driver or road inputs virtually instantaneously, helping to give greater control and minimising body roll, for a composed ride.



Electronic Air Suspension

Range Rover Sport features a next-generation four corner air suspension system which delivers class-leading comfort and capabilities both on and off-road. The air suspension system automatically switches between two ride heights when the off-road setting is selected. Maximum ground clearance is increased by 65mm above normal ride height at speeds less than 50kph.



Torque Vectoring

Torque Vectoring uses the electronic differential and vehicle's brake system to constantly balance the distribution of engine torque between the four wheels when cornering, resulting in improved grip, steering and reduced understeer whilst maintaining a consistent speed.

Vehicle shown left is HSE in Firenze Red.

Visit landrover.com for more information.

KEY FEATURES

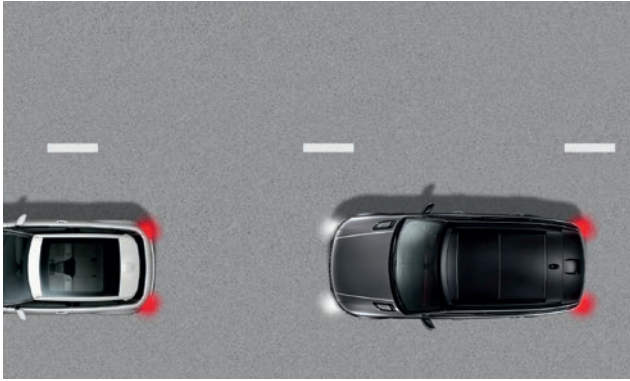

Adaptive Cruise Control with Queue Assist, Intelligent Emergency Braking and Active Seat Belts

Adaptive Cruise Control (ACC) is an improved cruise control system that helps maintain a pre-set gap from the vehicle in front, even if it changes speed. Queue Assist extends the ACC functionality. It is designed to allow the vehicle to come to a stop when it reaches a traffic queue.

Intelligent Emergency Braking uses radar to detect vehicles travelling in the same direction and automatically reduces impact speed if it calculates that a frontal collision is unavoidable.



Blind Spot Monitor with Closing Vehicle Sensing

Using sensors mounted on the sides and the rear bumper, these systems are designed to see what you might miss. When a vehicle enters a blind spot, a warning light will show in the corresponding door mirror.

Closing Vehicle Sensing scans a zone much further behind the vehicle, to help detect vehicles which are closing quickly from behind and which could cause a threat during a lane change manoeuvre.

Also available with Reverse Traffic Detection.

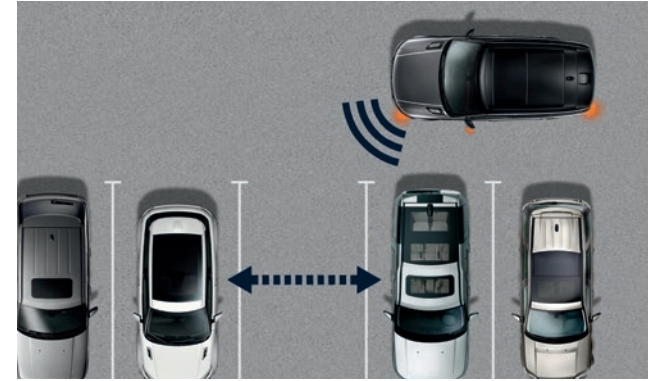

Park Assist

Range Rover Sport has been designed and engineered to meet the needs of today. Parking is made simpler with the aid of Parallel Parking, a feature which can be further enhanced with the addition of Parallel Exit, Perpendicular Parking and 360° Park Distance Control. Whether you're manoeuvring around tight corners or negotiating traffic, the vehicle is agile.

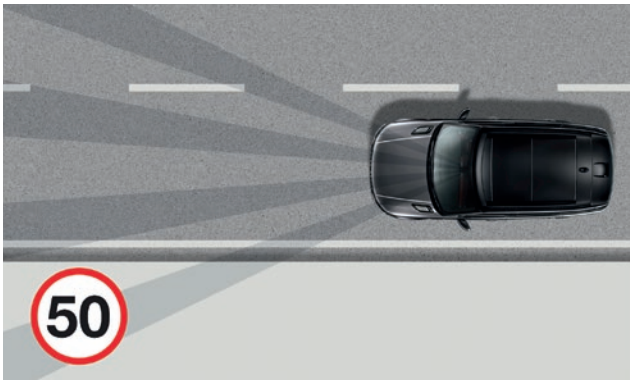

Traffic Sign Recognition with Lane Departure Warning

Traffic Sign Recognition uses the forward-looking camera to recognise speed limit signs and display the information in the instrument cluster.

Lane Departure Warning uses a forward-looking camera mounted in front of the rear view mirror to monitor lane markings on both sides of the vehicle. It gives a discrete warning in the form of a vibration through the steering wheel when the vehicle drifts out of its lane, triggering the indicators. (System operational at certain speeds).



Adaptive Xenon Headlamps (including headlamp powerwash)

Signature design LED lights combine distinctive design with highly practical capabilities: dynamic Xenon lamps swivel to follow the road, while static bending lamps light the kerbside area in tight bends to give the driver a greater sense of confidence during night-time driving.



Full Thin Film Transistor (TFT) Instrument Panel

The 12.3 inch virtual instrument panel uses state-of-the-art, high-resolution display technology and the latest colour graphics for clear communication of the main vehicle functions and data. With elegant virtual dials resembling 3D chrome it can be tailored to display only information that is relevant to the current driving situation.



Interior Mood Lighting

New levels of ambient refinement and personalisation have been reached with the option of customer configurable lighting. Using a combination of coloured LEDs, this feature allows occupants to vary the shade, changing the ambience of the cabin to suit their mood. There are ten colours in total to suit every taste and mood, ranging from Spark Blue through to Ice White and Racing Red.



Dual View Touch-Screen

Dual View technology enables driver and front passenger to view completely independent display content via the Touch-screen, so the passenger can watch TV while the driver follows navigational instructions.



Wade Sensing™

Using sensors in the wing mirrors when the vehicle is wading, it alerts the driver if the water is too deep. The feature is particularly useful when visibility is poor or when driving at night. This feature provides real-time pictorial wading information, including the depth of the water in relation to the vehicle, as well as maximum wading capability of the vehicle.



Audio

The Meridian™ audio technology gives you stunning sound quality. The top of the range system features Meridian Signature Reference Audio with 23 speakers including subwoofer and 3D surround sound.



Rear Seat Entertainment

The Rear Seat Entertainment System provides entertainment for rear passengers, with a choice of two eight-inch integrated or 10.2 inch video screens, a pair of WhiteFire® digital wireless headphones, one USB in the second row and a dedicated remote control.

It includes 'Journey Status', a Navigation Summary screen which displays a pop-up for the rear occupant detailing the time and distance to destination.



InControl™ Apps*

Land Rover InControl™ Apps enables you to use vehicle optimised smartphone apps on the vehicle's Touch-screen. Using the InControl Apps USB port you can enjoy a variety of vehicle optimised apps such as: Contacts, Calendar and Music Player, with more third party vehicle optimised apps being released over time. Your smartphone will also be re-charged whilst using InControl Apps.

*This feature is not available in all markets. Please consult your nearest Land Rover Dealer for details. WhiteFire® is a registered trademark of Unwired Technology LLC and any use of such marks by Land Rover is under licence.

DIMENSIONS AND CAPABILITIES



Wheelbase 2,923mm



Height 1,780mm

Front wheel track 1,690mm



Rear wheel track 1,685mm



Width 2,073mm mirrors folded
Width 2,220mm mirrors out

Obstacle Clearance

Off-road height 278mm
Standard ride height 213mm

Standard Ride Height

With roof rails 1,780mm
With roof antenna 1,801mm
With panoramic roof open 1,817mm
Access height air suspension setting will reduce each of the above by 50mm

Loadspace Capacity

Rear seats upright
Height 767mm, Width 1,285mm
Loadspace volume 784 litres
Loadspace width between arches 1,120mm
Length at floor 1,043mm-1,143mm

Rear seats forward
Height 767mm, Width 1,285mm
Loadspace volume 1,761 litres
Loadspace width between arches 1,120mm
Length at floor 1,871mm

Headroom

Maximum front headroom with LR2
Rear headroom 993mm



Overall length 4,850mm

Turning Circle

Kerb-to-kerb 12.3m
Wall-to-wall 12.5m
Turns lock-to-lock 2.78



	A	B	C
Ride Height			
Off-road (Hybrid)	33.0°	27.2° (25.9°)	31.0°
Standard (Hybrid)	24.3°	19.4° (18.9°)	24.9°



Wading Depth

Maximum wading depth 850mm

TECHNICAL SPECIFICATION / PERFORMANCE AND KEY DATA

	3.0L TDV6 DIESEL	3.0L SDV6 DIESEL	3.0L SDV6 HYBRID DIESEL	4.4L SDV8 DIESEL	3.0L V6 PETROL	5.0L V8 SUPERCHARGED PETROL
ENGINE DATA						
Capacity (cc)	2,993	2,993	2,993	4,367	2,995	4,999.7
No. of cylinders	6	6	6	8	6	8
Cylinder layout	Longitudinal V6	Longitudinal V6	Longitudinal V6	Longitudinal V8	Longitudinal V6	Longitudinal V8
Valves per cylinder	4	4	4	4	4	4
Bore (mm)	84	84	84	84	84.5	92.5
Stroke (mm)	90	90	90	98.5	89	93
Compression ratio (:1)	16.1	16.1	16.1	16.1	10.5	9.5
Maximum power kW (PS) / rpm	190 (258) / 4,000	215 (292) / 4,000	250 (340) / 4,000**	250 (339) / 3,500	250 (340) / 6,500	375 (510) / 6,000 – 6,500
Maximum torque Nm / rpm	600 / 2,000	600 / 2,000	700 / 1,500 – 3,000**	740 / 1,750 – 2,300	450 / 3,000 – 5,000	625 / 2,500 – 5,500
BRAKES						
Front type	Ventilated disc	Ventilated disc	Ventilated disc	Ventilated disc	Ventilated disc	Ventilated disc
Front diameter (mm)	350	380	380	380	350	380
Rear type	Ventilated disc	Ventilated disc	Ventilated disc	Ventilated disc	Ventilated disc	Ventilated disc
Rear diameter (mm)	350	365	365	365	350	365
WEIGHTS (kg)						
Weight	2,115	2,115	2,372	2,398	2,147	2,335
Maximum laden weight (5 seat / 5+2 Seating)	3,020 / 3,170	3,020 / 3,170	3,150 / 3,250	3,200 / 3,250	2,950	3,050 / 3,200
Maximum mass on each axle (front)	1,500	1,500	1,500	1,500	1,500	1,500
Maximum mass on each axle (rear) (5 seat / 5+2 Seating)	1,775 / 1,900	1,775 / 1,900	1,775 / 1,900	1,775 / 1,900	1,730	1,775 / 1,900
TOWING (kg)						
Unbraked Trailer	750	750	750	750	750	750
Maximum towing	3,500	3,500	3,000	3,500	3,500	3,500
Maximum coupling poiny /nose weight	150	150	120	150	150	150
Maximum vehicle and trailer combination / Gross Train Weight (5 seat / 5+2 Seating)	6,500 / 6,650	6,500 / 6,650	6,150 / 6,250	6,700 / 6,750	6,450	6,550 / 6,700
ROOF CARRYING (kg)						
Maximum roof load (including roof rails)	100	100	100	100	100	100
PERFORMANCE AND FUEL ECONOMY						
Maximum speed kph / mph	210 / 130	210 (222*) / 130 (138*)	210 (225*)	210 (225*)	210 / 130	225 (250*) / 140 (155*)
Acceleration (secs) 0-100kph	7.6	7.2	6.7	6.9	7.2	5.3
Acceleration (secs) 0-60 mph	7.1	6.8	6.4	6.5	6.9	5.0
Fuel tank capacity – usable (litres)	80	80	80	105	105	105
Diesel Particulate Filter (DPF)	■	■	■	■	–	–

*Only available on Dynamic Pack models. **When combined with electric motor.

■ Standard – Not Available.

ACCESSORIES





Deployable Side Steps*
 VPLWP0192, VPLWP0191, VPLWP0177, VPLWP0173 and either VPLWP0178, VPLWP0181 (Lane Departure equipped vehicles), VPLWP0179 (5+2 Seating equipped vehicles) or VPLWP0180 (5+2 Seating equipped vehicles with Lane Departure).

These smart, practical steps make it easier to get in and out of the vehicle. Neatly stowed under the sills, the Side Steps automatically deploy as soon as the door is opened, or when activated by the key fob. They stow automatically when the door is closed.



Fixed Side Step*
 VPLGP0226

The Fixed Side Steps aid entry and exit to the vehicle and improve access to the roof. Design features include Range Rover branding and bright anodised aluminium edge trim finish to complement vehicle styling cues. Compatible with Wade Sensing™ at 2015 model year. Vehicle software update allows compatibility for earlier model year vehicles.



Side Tubes*
 VPLWP0154

Manufactured from stainless steel with a highly polished finish, this product helps protect the vehicle in off-road conditions. Its rugged off-road appearance complements the vehicle's exterior design.



Stainless Steel Front Undershield
 VPLWP0162

The off-road inspired styled undershield features a premium bright polished finish for the front of the vehicle.



Stainless Steel Rear Undershield
 VPLWP0163

Stainless Steel Rear Undershield (Towing)**
 VPLWP0164



Body Side Mouldings
 VPLWP0159

Providing protection for your door panels from accidental damage by adjacent vehicles. Painted to match your vehicle's body colour, ensuring a premium finish and maintaining the overall aesthetics of your Range Rover Sport.

*Fitting of Side Steps or Side Tubes may affect the off-road capability of the vehicle.
 **Can be used with Electrically Deployable Tow Bar VPLWT0111.

ACCESSORIES



20 INCH FIVE SPLIT-SPOKE
'STYLE 520'
WITH GLOSS BLACK FINISH
VPLWW0090*



21 INCH FIVE SPLIT-SPOKE
'STYLE 507'
WITH GLOSS BLACK FINISH
VPLWW0091*



21 INCH FORGED NINE-SPOKE
'STYLE 705'
WITH FULL MACHINE POLISHED FINISH
VPLWW0083*



21 INCH FORGED NINE-SPOKE
'STYLE 705'
WITH LOW GLOSS FINISH
VPLWW0084*



21 INCH FORGED NINE-SPOKE
'STYLE 705'
WITH SATIN BLACK FINISH
VPLWW0085*



22 INCH FORGED FIVE SPLIT-SPOKE
'STYLE 514'
WITH MACHINE POLISHED FINISH
VPLWW0086*†

*Rim only. Centre caps available separately.
†Not available with 5+2 Seating.



22 INCH FORGED FIVE SPLIT-SPOKE
'STYLE 514'
WITH CERAMIC POLISHED FINISH
VPLWW0088*†



22 INCH FORGED FIVE SPLIT-SPOKE
'STYLE 514'
FULLY PAINTED WITH TECHNICAL GREY FINISH
VPLWW0087*†



22 INCH FORGED FIVE SPLIT-SPOKE
'STYLE 514'
FULLY PAINTED WITH LOW GLOSS BLACK FINISH
VPLWW0089*†

Accessory Wheels

A range of exclusive premium wheels offered for Range Rover Sport. Available in a variety of finishes and premium materials including forged aluminium. The wheels available are 20 inch, 21 inch and 22 inch.

ACCESSORIES



Stainless Steel Sports Pedals
VPLGS0160 – LHD
VPLGS0161 – RHD

Stainless Steel pedals feature a bright design and hidden fixings for a clean finish.



Premium carpet mats
LR041635 – Ebony – LHD
LR041633 – Ebony – RHD
LR041634 – Espresso – LHD
LR041632 – Espresso – RHD

2,050g weight deep pile carpet mats with waterproof backing.



Rubber floor mats
VPLWS0190 – LHD
VPLWS0189 – RHD

Rubber footwell mats for front and second row occupants help provide protection from general dirt.



Illuminated Treadplates
VPLWS0208

Illuminated treadplates are available on both the driver and front passenger sides of the vehicle to welcome you into the cabin.



Personalised Illuminated Treadplates
VPLWS0212 – Front
VPLWS0209 – Vehicle Set

You can personalise your vehicle further by adding a script of your choice in a variety of fonts which will be highlighted by subtle white illumination. Available as a full vehicle set (front pair personalised, rear pair illuminated only) or as a front pair only.



Door Sill Outer Treadplate
VPLWS0207

An aluminium enhancement for the outer door sills featuring a laser etched 'Sport' motif.



Luggage Divider – Full Height
VPLWS0235

The Luggage Divider is designed to prevent cargo from entering the passenger compartment. It incorporates a useful integral ski hatch that allows longer items to be carried where a suitable rear seat option is fitted.

Luggage Divider – Half Height
VPLWS0236

Luggage Divider – Loadspace Partition
VPLWS0237



Illuminated Rear Loadspace Treadplate Finisher
VPLWS0211PVJ – Ebony
VPLWS0211AAM – Espresso

Manufactured from stainless steel with a bright finish, protecting the loadspace trim when loading or unloading. Providing a premium finish to the loadspace with subtle illumination.



Rear Loadspace Treadplate Finisher
VPLWS0210PVJ – Ebony
VPLWS0210AAM – Espresso

Manufactured from stainless steel with a bright finish, protecting the loadspace trim when loading or unloading.



Loadspace Stowage Rails
VPLWS0242 – 5 Seat
VPLWS0243 – 5+2 Seating

Loadspace mounted rails to facilitate flexible stowage solutions. Loadspace Stowage Rails allow fitment of the Luggage Retention Kit.

Luggage Retention Kit
VPLGS0171

Pack of attachments that fix into the loadspace rails via a quick lock/quick release system to provide a flexible solution for retaining items. The attachment pack includes a retractable strap with inertia reel, telescopic rod and stowage bag.



Loadspace Mat – Rubber
VPLWS0225

Range Rover branded rubber mat helps to protect the rear loadspace carpet from general dirt. Rubber mat extension for protection of the back of the rear seats when folded down also available – Part No: VPLWS0223



Loadspace Liner Tray
VPLWS0224

This liner provides superior protection to the loadspace floor and side wall carpets from dirty or wet equipment.

ACCESSORIES



Roof Rails*
VPLWR0104 – Black Finish†
VPLWR0103 – Silver Finish††

Roof Rails facilitate easy fitment of cross bars. Pre-set positioning points ensure cross bars are fixed in optimum position for weight distribution and dynamics.

Maximum load capacity is 100kg and incremental height when fitted is 88mm.

Cross Bars*
VPLGR0102

T-track design utilises the full length of the bars, providing space to mount multiple accessories. Aerodynamic profile minimises drag and noise. Roof rails not included.



Luggage Carrier*
LR006848

Flexible rack system to facilitate roof carrying. Maximum payload 75kg.**

Roof Mounted Bike Carrier (not shown)*
VPLFR0091

Roof Mounted Bike Carrier – Fork Mounted with Wheel Carrier (not shown)*
VPLWR0101

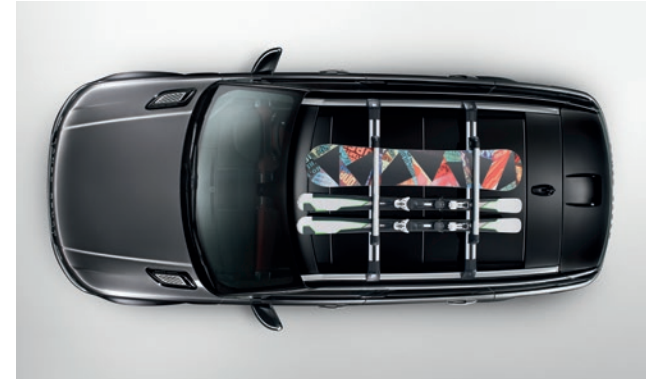

Ski/Snowboard Holder* – LR006849

Carries four pairs of skis or two snowboards. Lockable for security. Maximum payload 36kg.**

Aqua Sports Carrier (not shown) – VPLGR0107

Carries one surfboard, sailboard, canoe or kayak. Includes lockable multi-purpose holder to carry a mast, oars or paddles. Tilts to facilitate easy loading/unloading. Maximum payload 45kg.**



Large Sports Roof Box*
VPLWR0100

Featuring a quick mounting system for easy secure fixation. Includes integrated base mat with a non-slip surface for extra secure loading. Capable of carrying up to four pairs of skis or five snowboards. Volume 430 litres. Maximum payload 75kg.**



Luggage Box*
VPLVR0062

The gloss black finish Luggage Box opens from both sides and includes power-grip mounting for easy and quick fixing to the roof bars. Lockable for security. Volume 410 litres. Maximum payload 75kg.**



Tow Bar Mounted Bike Carrier
Two Bike Carrier – VPLVR0067 – LHD / VPLVR0066 – RHD
Three Bike Carrier – VPLVR0069 – LHD / VPLVR0068 – RHD
Four Bike Carrier – VPLVR0106 – LHD / VPLVR0105 – RHD

Tow bar mounted bike carrier available for two, three or four bikes. Featuring LED lighting, licence plate mount, a quick release design for ease of use and lockable for security. Maximum load capacity 60kg (on the four bike carrier).

Two Bike or Three Bike Carriers require a separate heat shield for fitment – Part No: VPLWR0124

Four Bike Carriers require a separate heat shield for fitment – Part No: VPLWR0123

*Roof Rails and Cross Bars are required for all Land Rover roof mounted accessories. Objects placed above the roof mounted satellite antenna may reduce the quality of the signal received by the vehicle and could have a detrimental effect on the navigation and satellite radio system, if fitted.

**Maximum payload equals the load capacity of the roof mounted accessory. †Roof Rail Ditch Finishers required for fitment with Black Finish Roof Rails – VPLWR0108.

††Roof Rail Ditch Finishers required for fitment with Silver Finish Roof Rails – VPLWR0109.

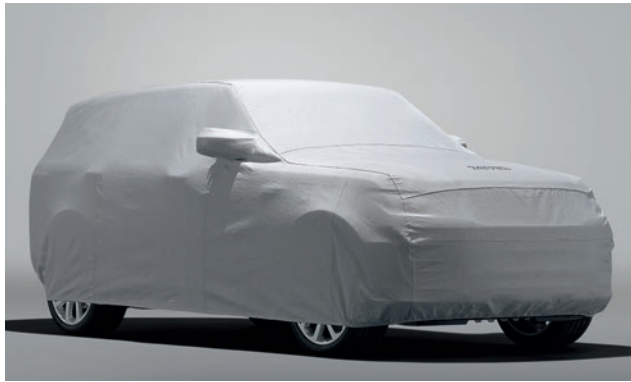

Outdoor Car Cover
VPLWC0061

All weather tailored cover protects your Range Rover Sport from the elements.



Windscreen Sun Shield
VPLWS0231

Helps to keep the vehicle interior cool in hot weather.



Noble Plated Mirror Caps
VPLGB0073

Noble Plated Mirror Caps complement the Range Rover Sport's exterior styling cues.

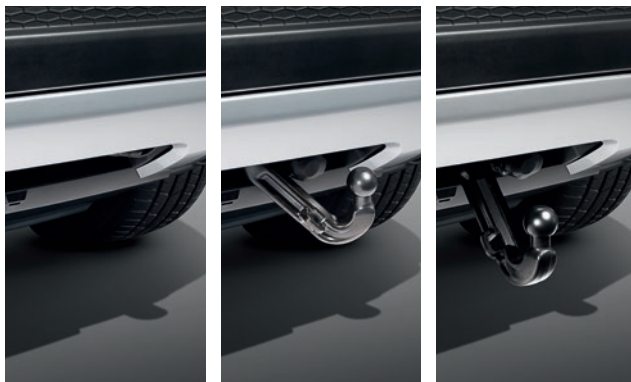

Electrically Deployable Tow Bar
VPLWT0111, VPLWT0123, VPLWT0122 and either VPLWB0140, VPLWB0135 or VPLWB0138

The Electrically Deployable Tow Bar is stowed discreetly behind the bumper, providing a clean attractive finish. It is designed to deploy/stow in 12 seconds. Approved for up to 3,500kg trailer load.



Multi-Height Tow Bar and Armature
VPLWT0159 and either VPLWB0139, VPLWB0136 or VPLWB0137

Bespoke Range Rover Sport system offers three different towing height options and the ability to swap heights in a matter of seconds. Approved for 3,500kg trailer load.



Towing Electrics – 13 Pin
VPLWT0114

European-style towing electrics, capable of supplying all trailer rear lighting and interior equipment power. Offered for Multi-Height Tow Bar.



Front Mudflaps
VPLWP0165

Front Mudflaps for Deployable Side Steps (not shown)
VPLWP0167

Rear Mudflaps
VPLWP0166

Mudflaps reduce spray and help protect the paintwork. Supplied as a pair.

*Towing load capacity on Hybrid is 3,000Kg.





BY APPOINTMENT TO
HER MAJESTY THE QUEEN
MANUFACTURERS OF
MOTOR VEHICLES
JAGUAR LAND ROVER LIMITED
COVENTRY



BY APPOINTMENT TO
HIS ROYAL HIGHNESS THE DUKE OF EDINBURGH
MANUFACTURERS OF
MOTOR VEHICLES
JAGUAR LAND ROVER LIMITED
COVENTRY



BY APPOINTMENT TO
HIS ROYAL HIGHNESS THE PRINCE OF WALES
MANUFACTURERS OF
MOTOR VEHICLES
JAGUAR LAND ROVER LIMITED
COVENTRY

IMPORTANT NOTICE: Jaguar Land Rover Limited is constantly seeking ways to improve the specification, design and production of its vehicles and alterations take place continually. Whilst every effort is made to produce up to date literature, this brochure should not be regarded as an infallible guide to current specifications, nor does it constitute an offer for the sale of any particular vehicle. Distributors and dealers are not agents of Jaguar Land Rover Limited by any express or implied undertaking or representation.

All Land Rover Approved Accessories fitted by a Land Rover Dealer within one month or 1,600 kilometres/1,000 miles (which ever occurs first) of the handover of a new registered vehicle will benefit from the same warranty terms and period of cover as the vehicle warranty. Accessories purchased outside of these parameters will be subject to a 12 month unlimited mileage warranty. All Land Rover Approved Accessories are rigorously tested to the same exacting standards as those applied to our vehicles. Performance in extreme hot and cold temperatures, corrosion resistance, impact and airbag deployment highlight some of the exhaustive product testing carried out to ensure accessories are both durable and importantly, continue to comply with current legislation.

All our accessories are designed to be an integral part of Land Rover vehicles. While many items such as roof carriers are simple to fit, some products require specialist tools and diagnostic equipment to ensure correct integration with the vehicle structure and electrical systems. These products vary from market to market, please consult your Land Rover Dealer who will be pleased to advise you on current specifications and any query you may have.

The colours reproduced here are subject to the limitations of the printing process and may therefore vary slightly from the actual vehicle. The company reserves the right to alter or withdraw any colour finish without notice. Some of these colours may not be obtainable in your country. Please check availability of colours and current specifications with your Land Rover Dealer. Distributors and dealerships are not agents of Jaguar Land Rover Limited and have absolutely no authority to bind Jaguar Land Rover Limited to any express or implied undertaking or representation.

Castrol EDGE Professional exclusively recommended by Land Rover.

Vehicle shown left is Autobiography with Dynamic Pack in Chile (Red).

Jaguar Land Rover Registered Office:
Abbey Road, Whitley, Coventry CV3 4LF
United Kingdom.

Registered in England: Number 1672070

landrover.com

© Jaguar Land Rover Limited 2014. Publication Number: LRML 4647/14

